



TOYOTA

V160

TRANSMISSION

REPAIR MANUAL

May, 1993

Pub.No.RM351E

FOREWORD

This repair manual has been prepared to provide information covering general service repairs for the V160 Manual Transmission.

Applicable models: JZA80 series

All information in this manual is based on the latest product information at the time of publication. However, specifications and procedures are subject to change without notice.

TOYOTA MOTOR CORPORATION

INTRODUCTION

HOW TO USE THIS MANUAL	IN- 2	
GENERAL REPAIR INSTRUCTIONS	IN- 5	
ABBREVIATIONS USED		
IN THIS MANUAL	IN- 7	
STANDARD BOLT TORQUE		
SPECIFICATIONS	IN- 8	

HOW TO USE THIS MANUAL

To assist you in finding your way through the manual, the Section Title and major heading are given at the top of every page.

PREPARATION

Preparation lists the SST (Special Service Tools), recommended tools, equipment, lubricant and SSM (Special Service Materials) which should be prepared before beginning the operation and explains the purpose of each one.

REPAIR PROCEDURES

Most repair operations begin with an overview illustration. It identifies the components and shows how the parts fit together.

Example:

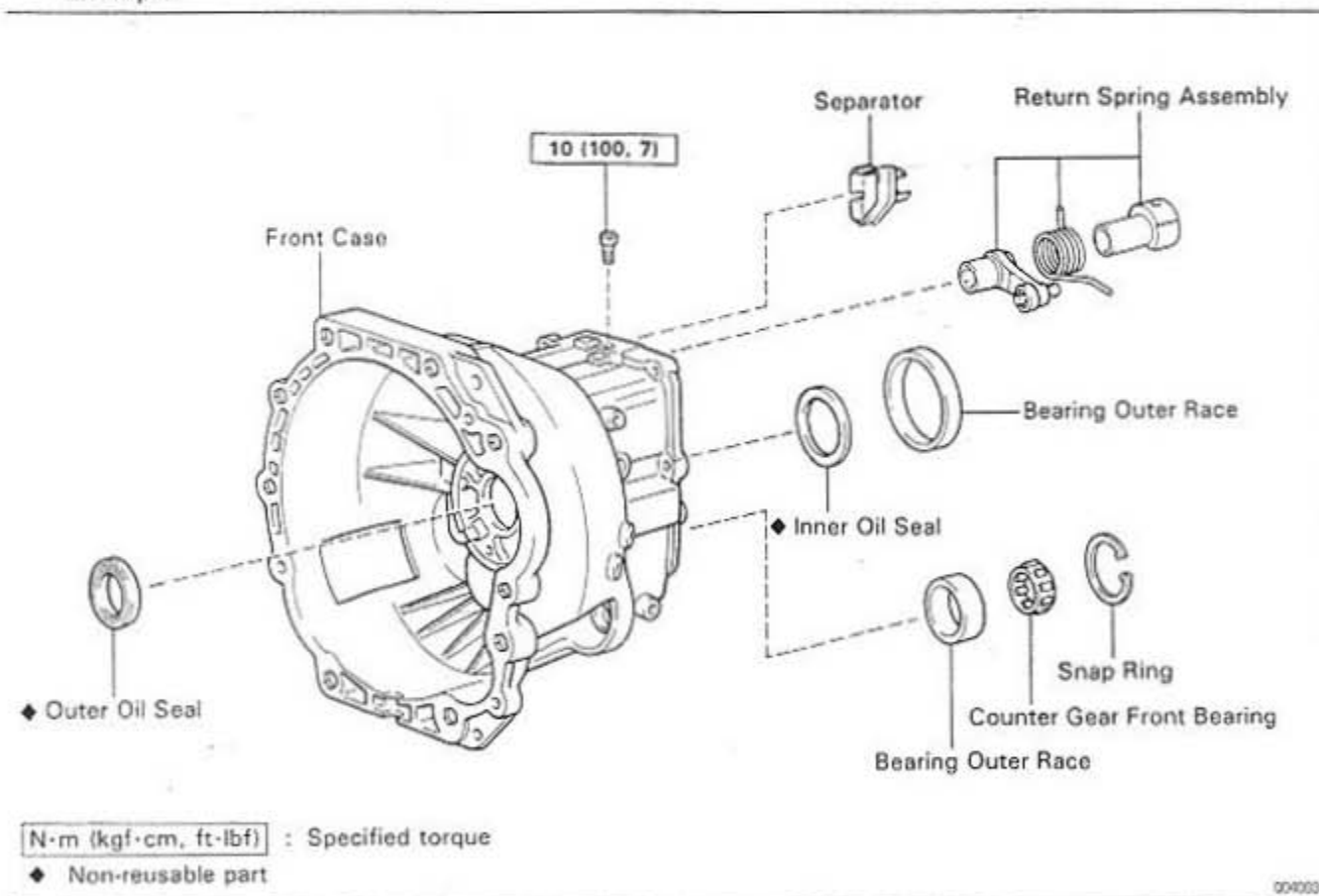

The procedures are presented in a step-by-step format:

- The illustration shows what to do and where to do it.
- The task heading tells what to do.
- The detailed text tells how to perform the task and gives other information such as specifications and warnings.

Example:

Task heading: what to do

21. CHECK PISTON STROKE OF OVERDRIVE BRAKE

(a) Place SST and a dial indicator onto the overdrive brake piston as shown in the illustration.

SST 09350-30020 (09350-06120)

Set part No. *Component part No.*

Detailed text: how to do task

(b) Measure the stroke applying and releasing the compressed air (392 – 785 kPa, 4 – 8 kgf/cm² or 57 – 114 psi) as shown in the illustration.

Piston stroke: 1.40 – 1.70 mm (0.0551 – 0.0669 in.)

Specification

Illustration: what to do and where

This format provides the experienced technician with a **FAST TRACK** to the information needed. The upper case task heading can be read at a glance when necessary, and the text below it provides detailed information. Important specifications and warnings always stand out in bold type.

REFERENCES

References have been kept to a minimum. However, when they are required you are given the page to refer to.

SPECIFICATIONS

Specifications are presented in bold type throughout the text where needed. You never have to leave the procedure to look up your specifications. They are also found at the back of AX section, for quick reference.

CAUTIONS, NOTICES, HINTS:

- **CAUTIONS** are presented in bold type, and indicate there is a possibility of injury to you or other people.
- **NOTICES** are also presented in bold type, and indicate the possibility of damage to the components being repaired.
- **HINTS** are separated from the text but do not appear in bold. They provide additional information to help you perform the repair efficiently.

SI UNIT

The **UNITS** given in this manual are primarily expressed according to the **SI UNIT** (International System of Unit), and alternately expressed in the metric system and in the English system.

Example:

Torque: **30 N·m (310 kgf·cm, 22 ft·lbf)**

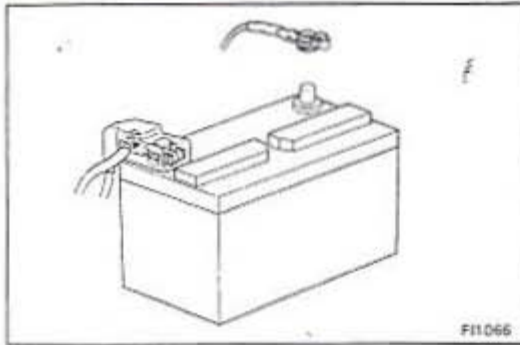

GENERAL REPAIR INSTRUCTIONS

1. Use fender, seat and floor covers to keep the vehicle clean and prevent damage.
2. During disassembly, keep parts in the appropriate order to facilitate reassembly.
3. Observe the following:
 - (a) Before performing electrical work, disconnect the negative cable from the battery terminal.
 - (b) If it is necessary to disconnect the battery for inspection or repair, always disconnect the cable from the negative (-) terminal which is grounded to the vehicle body.
 - (c) To prevent damage to the battery terminal post, loosen the terminal nut and raise the cable straight up without twisting or prying it.
 - (d) Clean the battery terminal posts and cable terminals with a clean shop rag. Do not scrape them with a file or other abrasive objects.
 - (e) Install the cable terminal to the battery post with the nut loose, and tighten the nut after installation. Do not use a hammer to tap the terminal onto the post.
 - (f) Be sure the cover for the positive (+) terminal is properly in place.
4. Check hose and wiring connectors to make sure that they are secure and correct.
5. Non-reusable parts
 - (a) Always replace cotter pins, gaskets, O-rings and oil seals etc. with new ones.
 - (b) Non-reusable parts are indicated in the component illustrations by the "◆" symbol.



6. Precoated parts

Precoated parts are bolts and nuts, etc. that are coated with a seal lock adhesive at the factory.

 - (a) If a precoated part is retightened, loosened or caused to move in any way, it must be recoated with the specified adhesive.

- (b) When reusing precoated parts, clean off the old adhesive and dry with compressed air. Then apply the specified seal lock adhesive to the bolt, nut or threads.
 - (c) Precoated parts are indicated in the component illustrations by the "★" symbol.
7. When necessary, use a sealer on gaskets to prevent leaks.
 8. Carefully observe all specifications for bolt tightening torques. Always use a torque wrench.
 9. Use of special service tools (SST) and special service materials (SSM) may be required, depending on the nature of the repair. Be sure to use SST and SSM where specified and follow the proper work procedure. A list of SST and SSM can be found at the preparation of AX section.

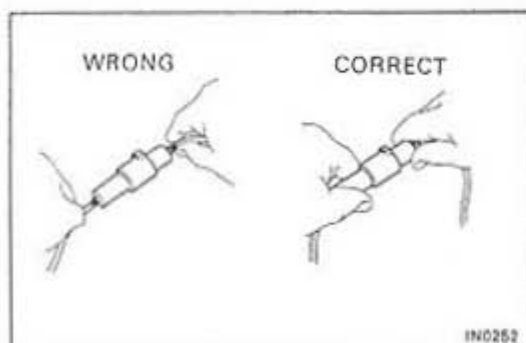
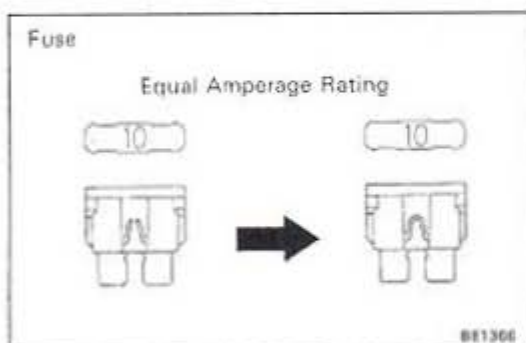

10. When replacing fuses, be sure the new fuse has the correct amperage rating. **DO NOT** exceed the rating or use one with a lower rating.
11. To pull apart electrical connectors, pull on the connector itself, not the wires.
12. Care must be taken when jacking up and supporting the vehicle. Be sure to lift and support the vehicle at the proper locations.
 - (a) If the vehicle is to be jacked up only at the front or rear end, be sure to block the wheels at the opposite end in order to ensure safety.
 - (b) After the vehicle is jacked up, be sure to support it on stands. It is extremely dangerous to do any work on a vehicle raised on a jack alone, even for a small job that can be finished quickly.

ABBREVIATIONS USED IN THIS MANUAL









INTN-01

in.	inch
MP	Multipurpose
SSM	Special Service Materials
SST	Special Service Tools

STANDARD BOLT TORQUE SPECIFICATIONS

IN004-02

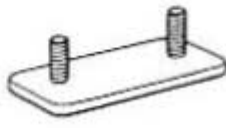
HOW TO DETERMINE BOLT STRENGTH

	Mark	Class		Mark	Class
Hexagon head bolt	 <p>Bolt head No.</p> <p>4— 4T 5— 5T 6— 6T 7— 7T 8— 8T 9— 9T 10— 10T 11— 11T</p>		Stud bolt	 <p>No mark</p>	4T
	 <p>No mark</p>	4T			
Hexagon flange bolt w/ washer hexagon bolt	 <p>No mark</p>	4T	Welded bolt	 <p>Grooved</p>	6T
Hexagon head bolt	 <p>2 protruding lines</p>	5T			
Hexagon flange bolt w/ washer hexagon bolt	 <p>2 protruding lines</p>	6T		4T	
Hexagon head bolt	 <p>3 protruding lines</p>	7T			
Hexagon head bolt	 <p>4 protruding lines</p>	8T			

SPECIFIED TORQUE FOR STANDARD BOLTS

Class	Diameter mm	Pitch mm	Specified torque					
			Hexagon head bolt			Hexagon flange bolt		
			N·m	kgf·cm	ft·lbf	N·m	kgf·cm	ft·lbf
4T	6	1	5	55	48 in.·lbf	6	60	52 in.·lbf
	8	1.25	12.5	130	9	14	145	10
	10	1.25	26	260	19	29	290	21
	12	1.25	47	480	35	53	540	39
	14	1.5	74	760	55	84	850	61
	16	1.5	115	1,150	83	—	—	—
5T	6	1	6.5	65	56 in.·lbf	7.5	75	65 in.·lbf
	8	1.25	15.5	160	12	17.5	175	13
	10	1.25	32	330	24	36	360	26
	12	1.25	59	600	43	65	670	48
	14	1.5	91	930	67	100	1,050	76
	16	1.5	140	1,400	101	—	—	—
6T	6	1	8	80	69 in.·lbf	9	90	78 in.·lbf
	8	1.25	19	195	14	21	210	15
	10	1.25	39	400	29	44	440	32
	12	1.25	71	730	53	80	810	59
	14	1.5	110	1,100	80	125	1,250	90
	16	1.5	170	1,750	127	—	—	—
7T	6	1	10.5	110	8	12	120	9
	8	1.25	25	260	19	28	290	21
	10	1.25	52	530	38	58	590	43
	12	1.25	95	970	70	105	1,050	76
	14	1.5	145	1,500	108	165	1,700	123
	16	1.5	230	2,300	166	—	—	—
8T	8	1.25	29	300	22	33	330	24
	10	1.25	61	620	45	68	690	50
	12	1.25	110	1,100	80	120	1,250	90
9T	8	1.25	34	340	25	37	380	27
	10	1.25	70	710	51	78	790	57
	12	1.25	125	1,300	94	140	1,450	105
10T	8	1.25	38	390	28	42	430	31
	10	1.25	78	800	58	88	890	64
	12	1.25	140	1,450	105	155	1,600	116
11T	8	1.25	42	430	31	47	480	35
	10	1.25	87	890	64	97	990	72
	12	1.25	155	1,600	116	175	1,800	130

V160 MANUAL TRANSMISSION

DESCRIPTION	MT- 2
OPERATION	MT- 3
PREPARATION	MT- 4
TROUBLESHOOTING	MT- 7
PRECAUTION	MT- 8
COMPONENT PARTS REMOVAL	MT- 9
INPUT SHAFT	MT- 20
OUTPUT SHAFT	MT- 23
COUNTER GEAR	MT- 36
FRONT CASE	MT- 37
INTERMEDIATE PLATE	MT- 42
REAR CASE	MT- 44
COMPONENT PARTS INSTALLATION	MT- 50
SERVICE SPECIFICATIONS	MT- 62

DESCRIPTION

GENERAL

MUTEX-2F

- A triple-cone type synchromesh mechanism is used for 1st and 2nd gears and a double-cone type synchromesh mechanism is used 3rd and 4th gears to improve the shift feeling characteristics. This helps to reduce the shifting effort, providing a smooth shift.
- A reverse synchromesh mechanism is used to suppress gear engagement noise in reverse gear shifting while providing a smooth shift.

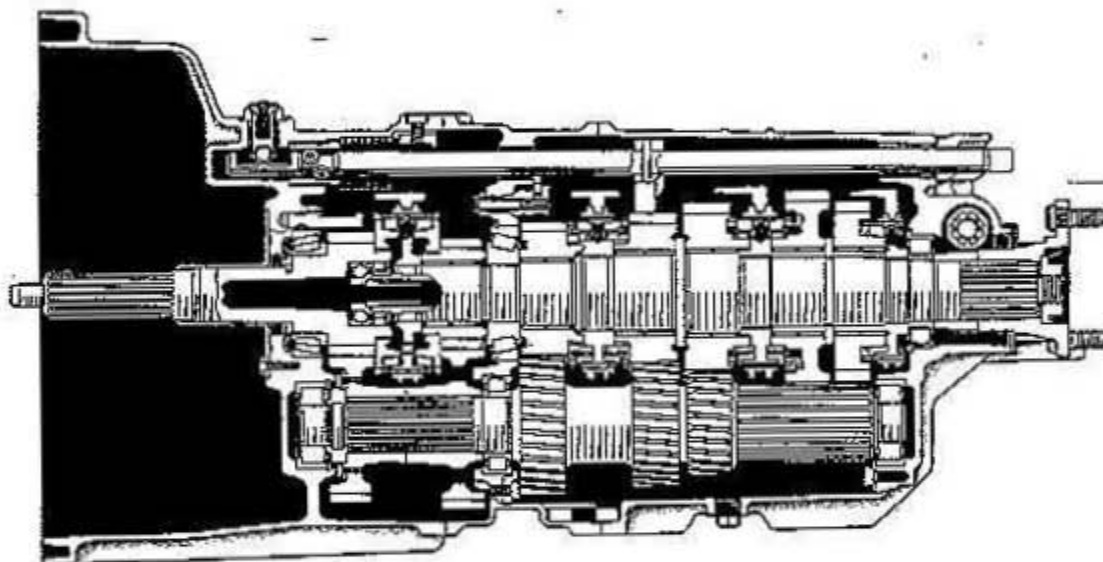

003652

104700

Type of Transmission	V160	
Type of Engine	2JZ-GTE	
Gear Ratio	1st gear	3.827
	2nd gear	2.360
	3rd gear	1.685
	4th gear	1.312
	5th gear	1.000
	5th gear	0.793
	Reverse gear	3.280
Oil Type	TOYOTA GEAR OIL V160 or equivalent	
Oil Capacity	1.8 liters (1.9 US qts, 1.6 Imp. qts)	

OPERATION



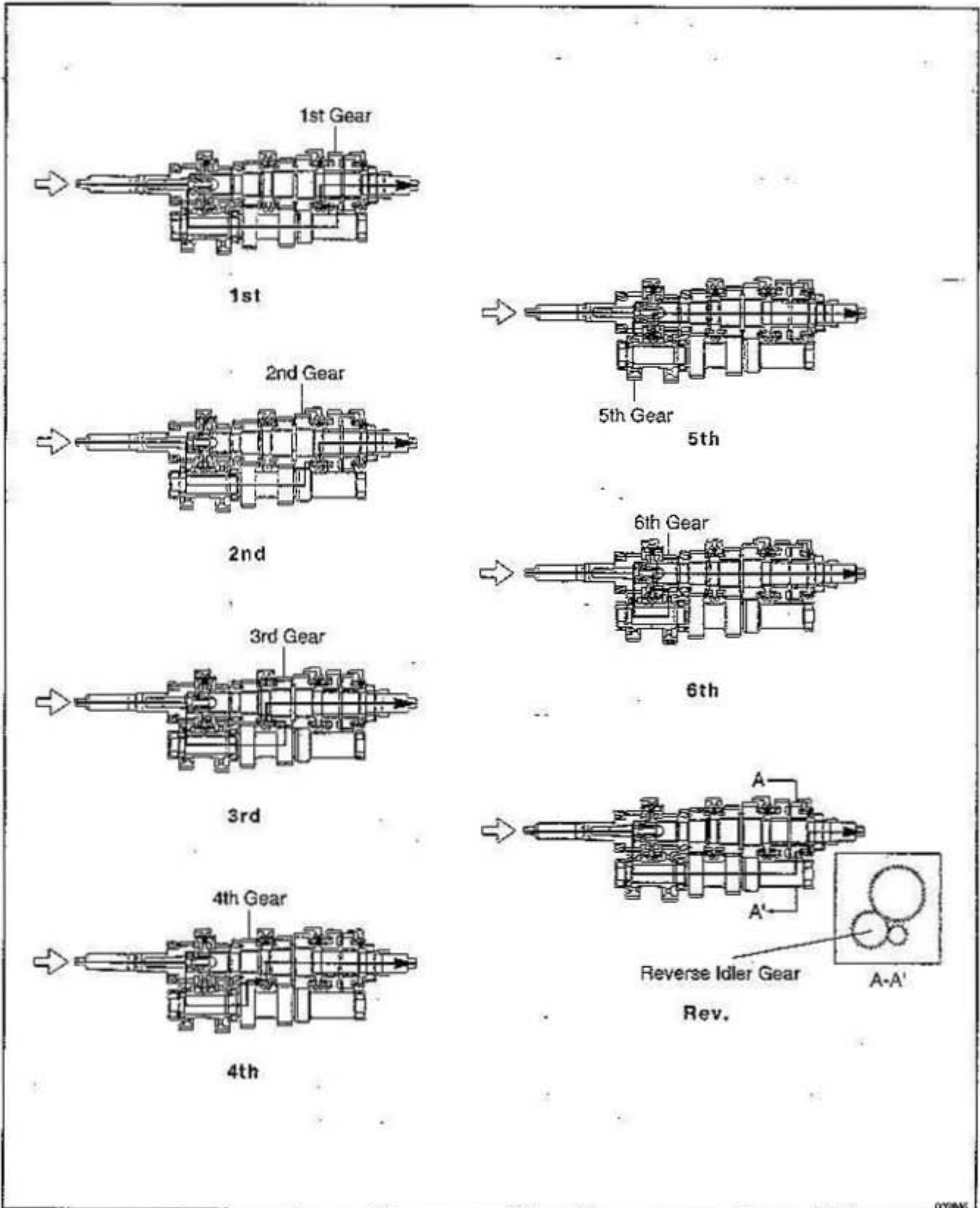









- The illustration below show the engagements of transmission gears.



PREPARATION





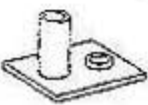





SST (SPECIAL SERVICE TOOLS)

MT111-00



	09213-60017 Crankshaft Pulley & Gear Puller Set	5-6 Clutch hub
	(09213-00020) Body With Bolt	
	(09213-00030) Handle	
	(09213-00090) Bolt Set	
	09213-27010 Gear Remover	
	09308-14010 Replacer Pipe A	
	09308-14030 Replacer B	
	09309-14010 Remover & Replacer A	
	09309-14020 Remover & Replacer B	
	09309-14030 Remover & Replacer C	
	09309-14040 Remover & Replacer D	
	09309-14050 Remover & Replacer E	
	09310-14010 Stand	

MANUAL TRANSMISSION – PREPARATION

MT-5

	<p>09330-00021 Companion Flange Holding Tool</p>	
	<p>09950-00020 Bearing Remover</p>	
	<p>09631-20031 Oil Seal "B" Remover</p>	
	<p>09817-16011 Back-up Light Switch Tool</p>	
	<p>09950-20017 Universal Puller</p>	
	<p>09950-30010 Puller A Set</p>	
	<p>(09951-03010) Upper Plate</p>	
	<p>(09953-03010) Center Bolt</p>	
	<p>(09954-03010) Arm</p>	
	<p>(09955-03030) Lower Plate 130</p>	
	<p>(09956-03030) Adaptor 20</p>	

RECOMMENDED TOOLS

	09031-00030 Pin Punch	
	09905-00012 Snap Ring No. 1 Expander	
	09924-12411 Deep Socket 41	

EQUIPMENT

Calipers	
Dial indicator	
Micrometer	
Torque wrench	
Feeler gauge	

LUBRICANT

Item	Capacity	Classification
Manual transmission oil	1.8 liters (1.9 US qts, 1.6 imp.qts)	TOYOTA GEAR OIL V160 or equivalent

SSM (SPECIAL SERVICE MATERIALS)

08826-00090 Seal Packing 1281, THREE BOND 1281 or equivalent (FIG)	Front case x Intermediate plate Rear case x Intermediate plate
08833-00080 Adhesive 1344, THREE BOND 1344, LOCTITE 242 or equivalent	Return lever set bolt Reverse idler gear shaft set bolt Companion flange lock nut Lock ball assembly

TROUBLESHOOTING

Use the table below to help you find the cause of the problem. The numbers indicate the priority of the likely cause of the problem. Check each part in order. If necessary, replace these parts.

See Page	1	MT-2	1	MT-9	MT-9	MT-9	1	MT-9	MT-10	MT-9	MT-9	MT-20, 23	MT-23				
Parts Name																	
Trouble	Oil (Level low)	Oil (Wrong)	Oil (Level too high)	Gasket (Damaged)	Oil seal (Worn or damaged)	O-Ring (Worn or damaged)	Control cable (Faulty)	Locking ball spring (Damaged)	Shift fork (Worn)	Gear (Worn or damaged)	Bearing (Worn or damaged)	Synchronizer ring (Worn or damaged)	Shifting key spring (Damaged)				
Noise	1	2								3	3						
Oil leakage			1	2	2	3											
Hard to shift or will not shift							1					2	3				
Jumps out of gear								1	2	3	3						

PRECAUTION

When working with FIGP material, you must observe the following.

MT8-02

- Using a razor blade and gasket scraper, remove all the old FIGP material from the gasket surfaces.
- Thoroughly clean all components to remove all the loose material.
- Clean both sealing surfaces with a non-residue solvent.
- Apply the FIGP in an approx. 1 mm (0.04 in.) wide bead along the sealing surface.
- Parts must be assembled within 10 minutes of application. Otherwise, the FIGP material must be removed and reapplied.

COMPONENT PARTS REMOVAL COMPONENTS

MTM-01

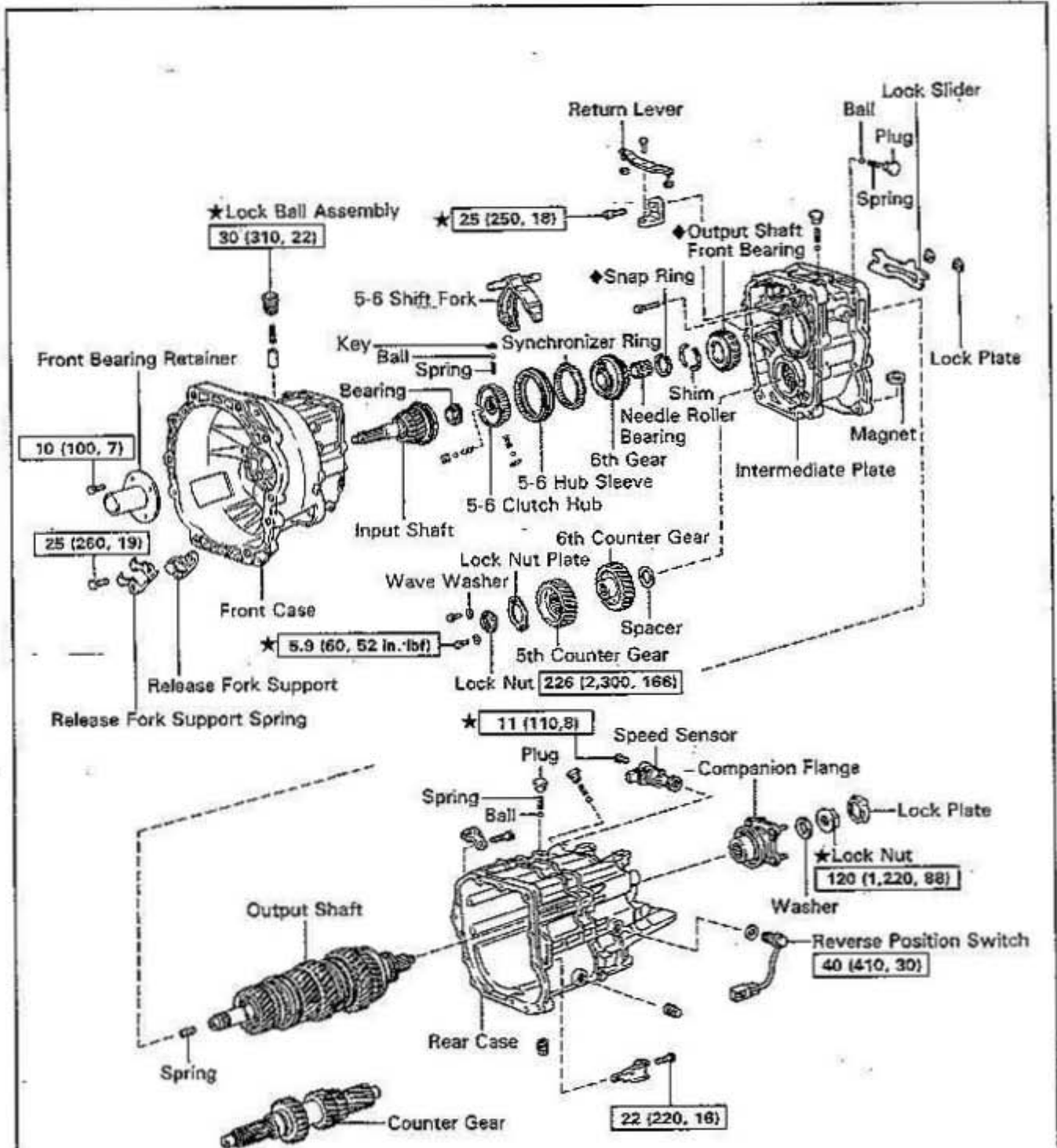

N·m (kgf·cm, ft·lbf) : Specified torque

◆ Non-reusable part

★ Precoated part

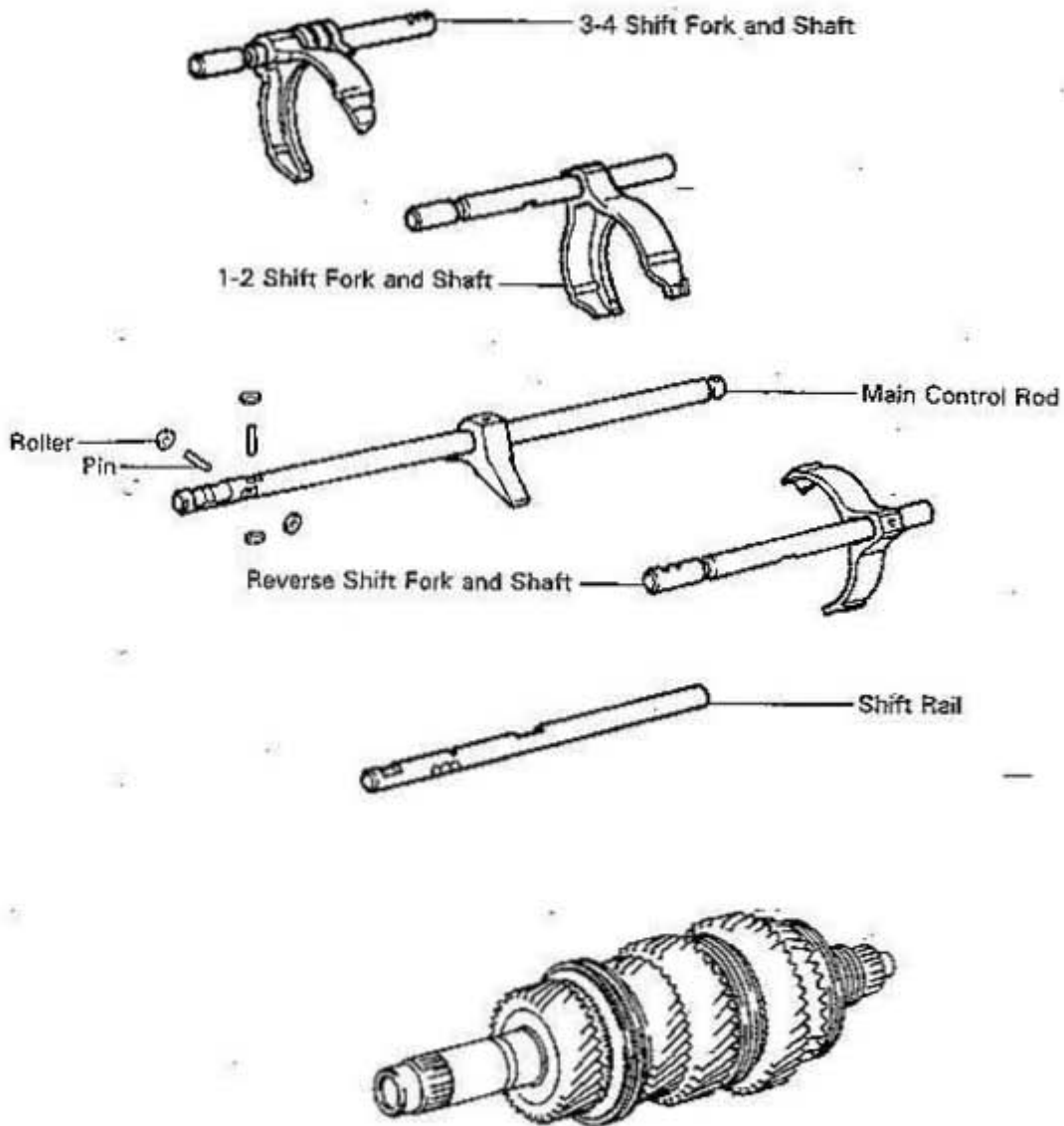

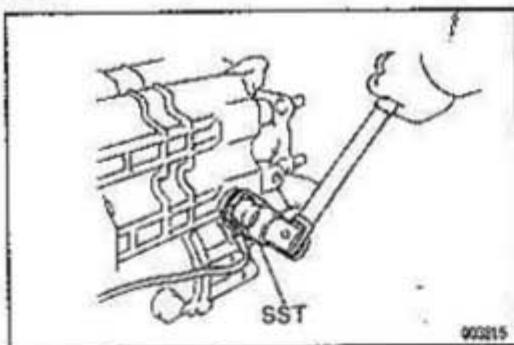

BASIC SUBASSEMBLY SEPARATION

1. **INSPECT NEUTRAL POSITION**
2. **REMOVE BACK-UP LIGHT SWITCH**
Using SST, remove the back-up light switch and gasket.
SST 09817-16011

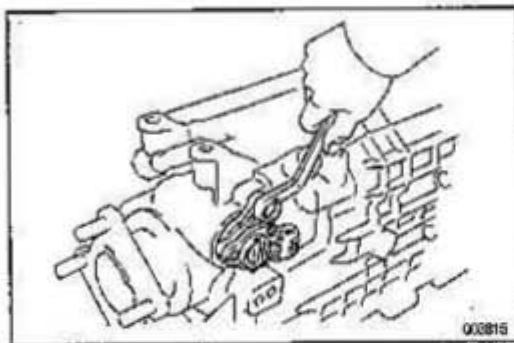

3. **REMOVE SPEED SENSOR DRIVEN GEAR**
 - (a) Remove the set bolt and driven gear.
 - (b) Remove the O-ring from the driven gear.

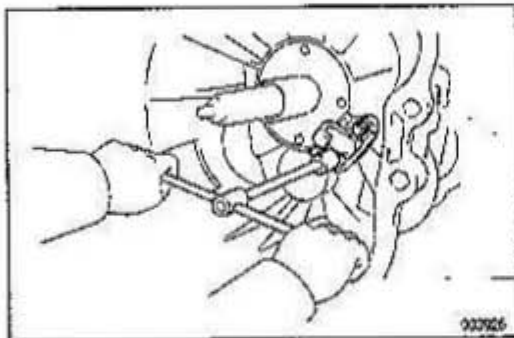

4. **REMOVE FRONT BEARING RETAINER**
 - (a) Remove the 2 bolts and clutch release fork support.

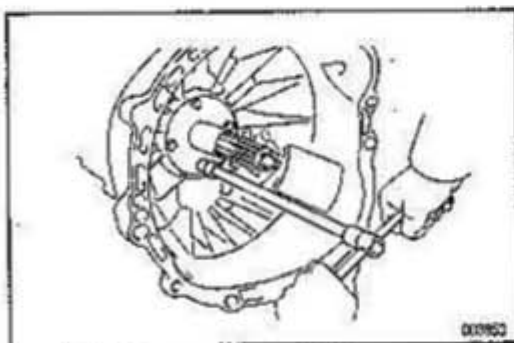

- (b) Remove the 4 bolts.

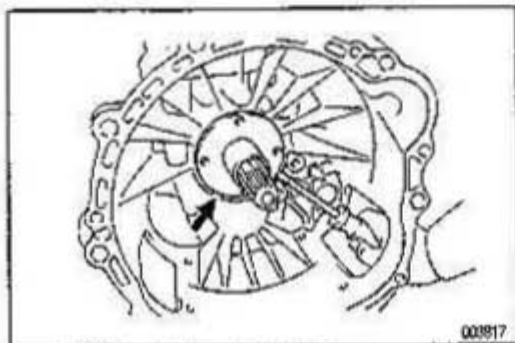

- (c) Using a screwdriver, remove the front bearing retainer.

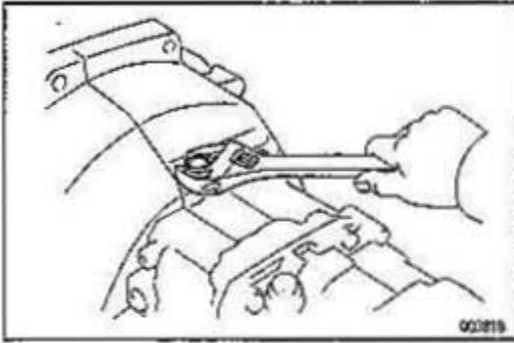
**5. REMOVE LOCK BALL ASSEMBLY**

(a) Remove the plug.

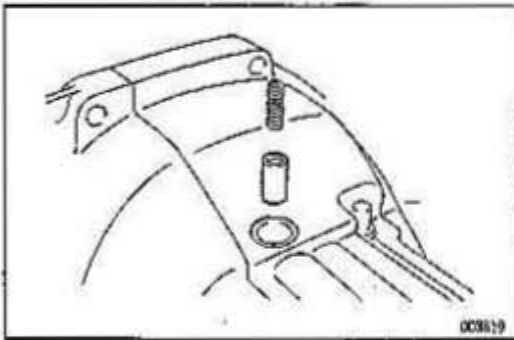

(b) Remove the spring and spring seat.

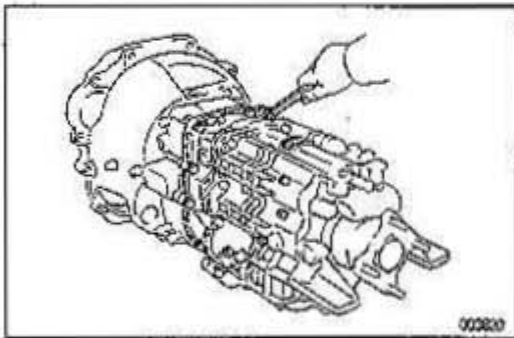
**6. REMOVE FRONT CASE**

(a) Remove the 11 bolts.

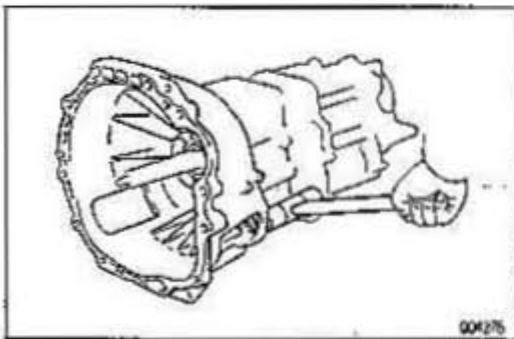

(b) Using a plastic hammer, carefully tap the front case.

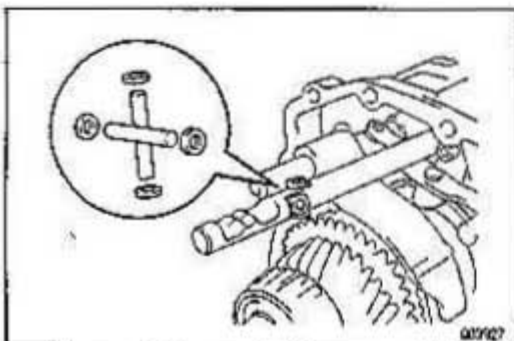
(c) Pull out the front case from the intermediate plate.
NOTICE: Take care to avoid dropping the 4 rollers when you remove the main control rod.**7. REMOVE ROLLERS AND PINS**

Remove the 4 rollers and 2 pins from the main control rod.

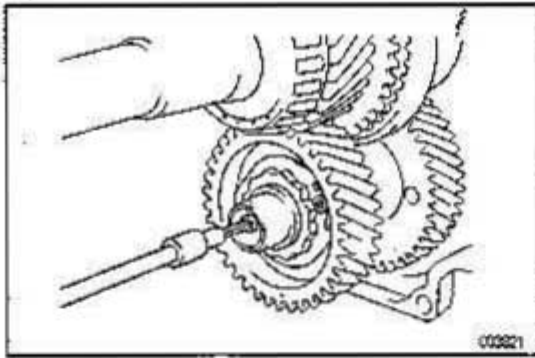

- 8. REMOVE INPUT SHAFT AND 5TH COUNTER GEAR**
 (a) Using a hexagon wrench, remove the 2 bolts and washers.

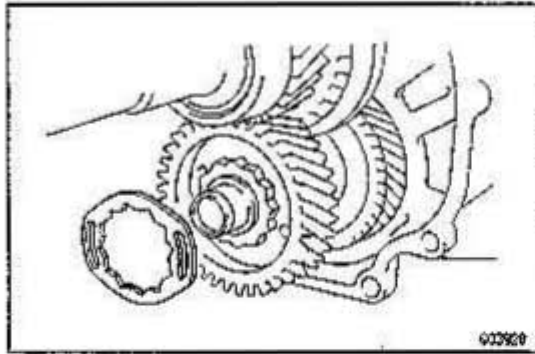

- (b) Remove the lock nut plate.

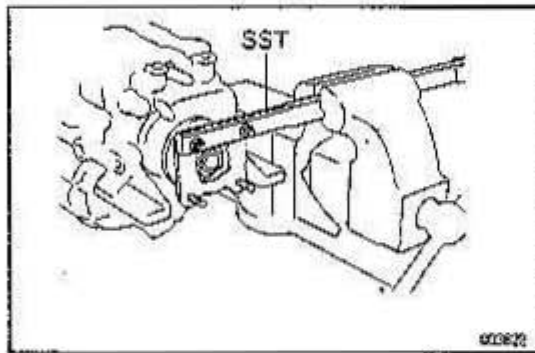

- (c) Using SST, set the transmission as shown in the illustration.
 SST 09330-00021
 (d) Engage the gear.

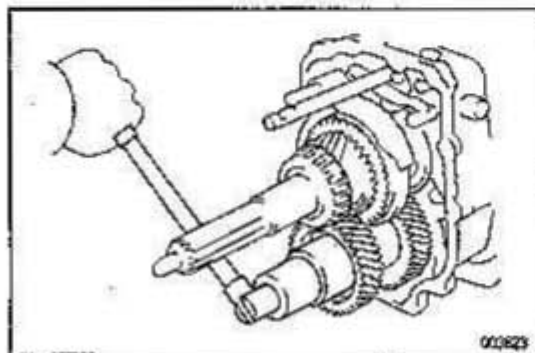

- (e) Using a deep socket wrench, remove the lock nut.

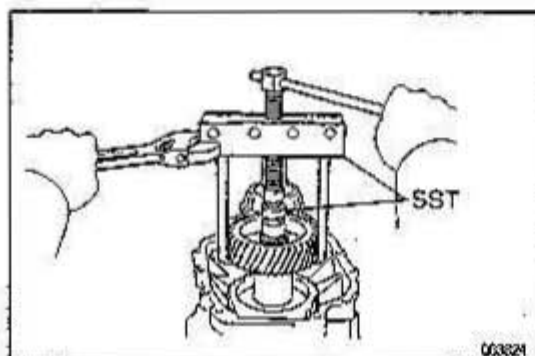

- (f) Using SST, remove the counter 5th gear together with the input shaft.
 SST 09213-27010, 09631-20031

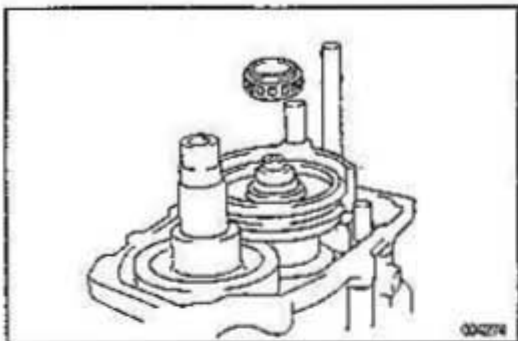

9. REMOVE OUTPUT SHAFT FRONT BEARING

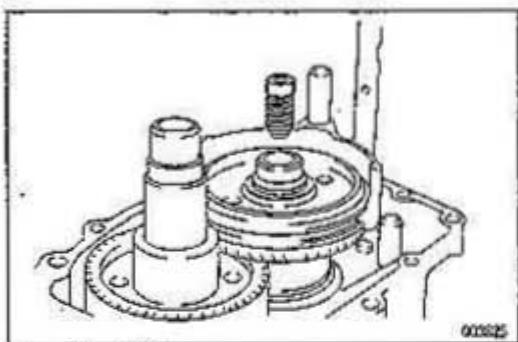

10. REMOVE SPRING FOR ADJUSTING PRELOAD

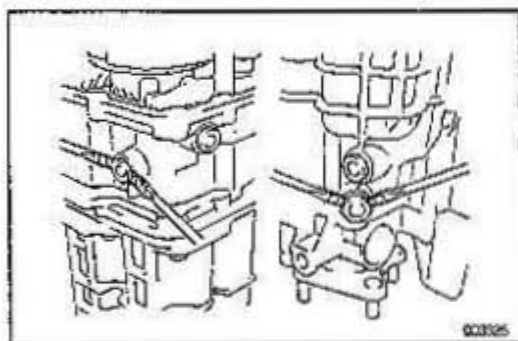

11. REMOVE LOCK BALLS

(a) Using 2 screwdrivers, pull the 4 plugs out straight.

HINT: Tape the screwdriver tip before use.

(b) Using a magnetic finger, remove the 4 springs and 4 balls.

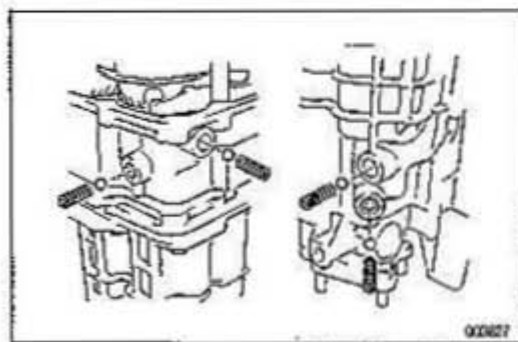

12. MEASURE 6TH GEAR THRUST CLEARANCE

Using a feeler gauge, measure the 6th gear thrust clearance.

Maximum clearance:

0.33 mm (0.0130 in.)

If the clearance more than the limit, replace the gear.

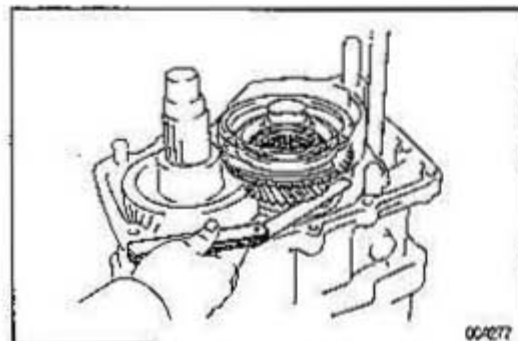

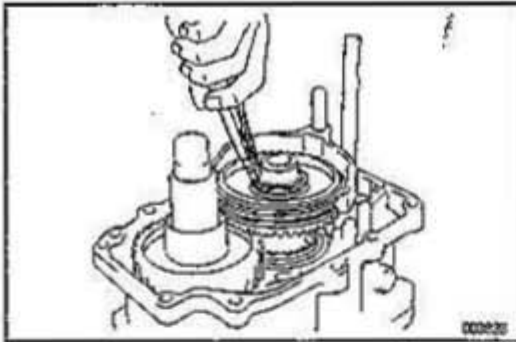

13. REMOVE 6TH GEAR

- (a) Using a snap ring expander, remove the snap ring.
NOTICE: Take care to not scratch the output shaft.

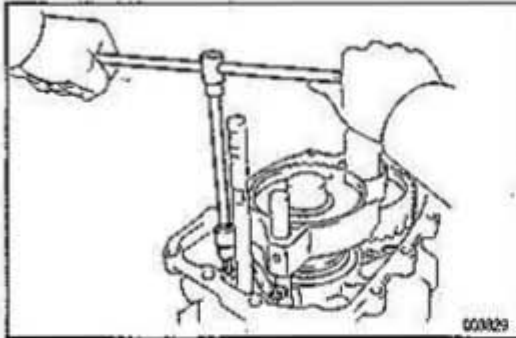

- (b) Using a hexagon wrench, remove the return lever set bolt.

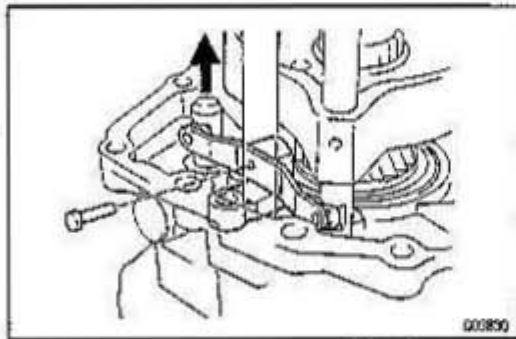

- (c) Remove the return lever.
HINT: Lift up the shift rail before removing the return lever.

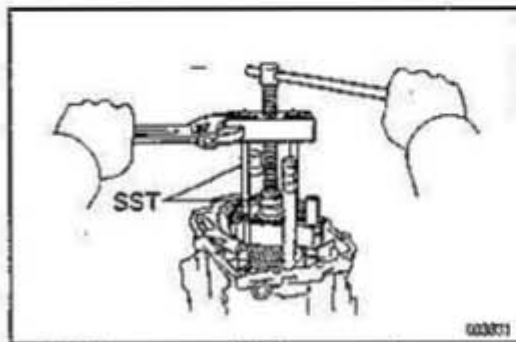

- (d) Using SST, remove the 5-6 clutch hub, shift fork and fork shaft.

SST 09213-60017 (09213-00020, 09213-00030, 09213-00090) 09631-20031

NOTICE: Take care that the hub sleeve does not come apart from the clutch hub when you remove it.

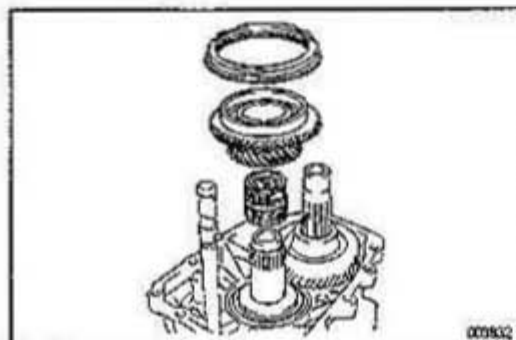

- (e) Remove the 6th gear, synchronizer ring and needle roller bearing.

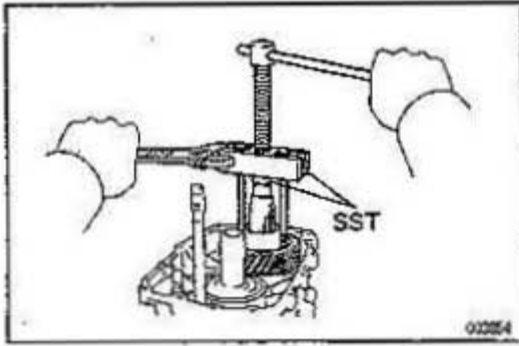
**14. REMOVE 6TH COUNTER GEAR**

- (a) Using SST, remove the counter 6th gear.
SST 09213-60017 (09213-00020, 09213-00030,
09213-00090) 09213-20031

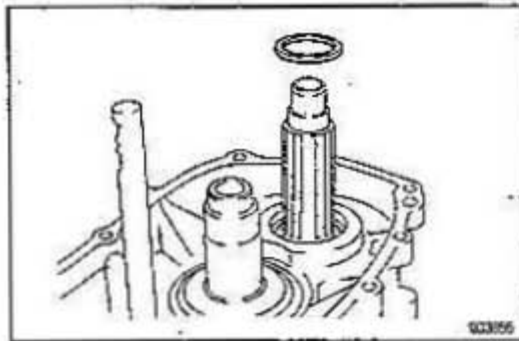

- (b) Remove the spacer from the counter gear shaft.

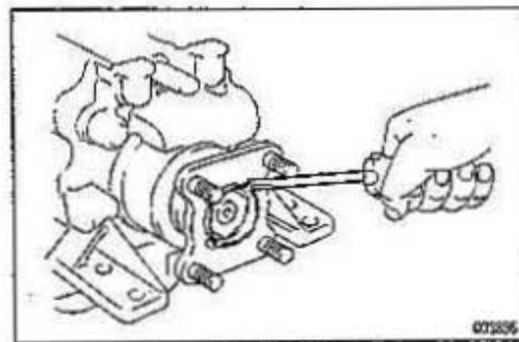
**15. REMOVE COMPANION FLANGE**

- (a) Using a screwdriver, remove the lock plate.

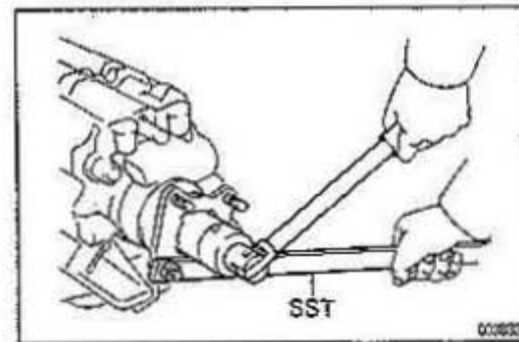

- (b) Using SST to hold the flange, remove the lock nut.
SST 09330-00021

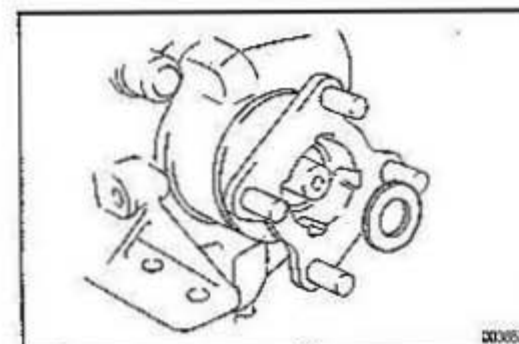

- (c) Remove the 2 washers.

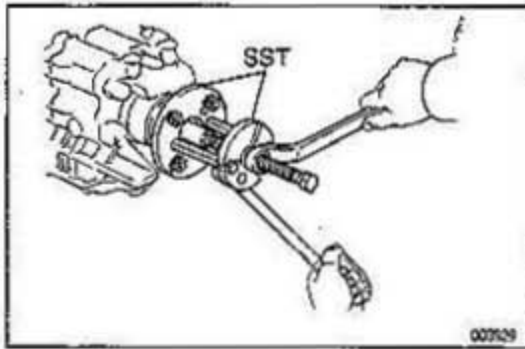

- (d) Using SST, remove the companion flange.
 SST 09950-30010 (09951-03010, 09953-03010,
 09954-03010, 09955-03030, 09956-03030)

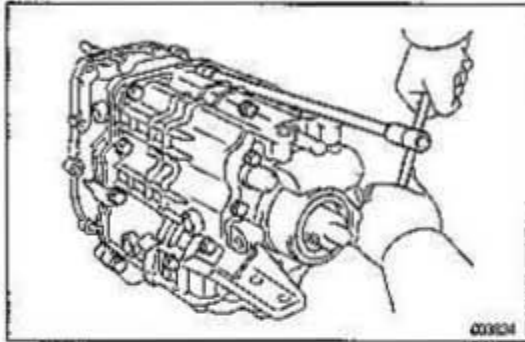

- 16. REMOVE REAR CASE**
 (a) Remove the 10 bolts.

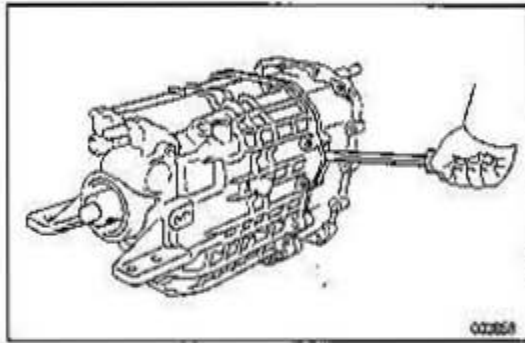

- (b) Using a screwdriver, prize the rear case.
 HINT: Tape the screwdriver tip before use.
 (c) Pull out the rear case from the intermediate plate.

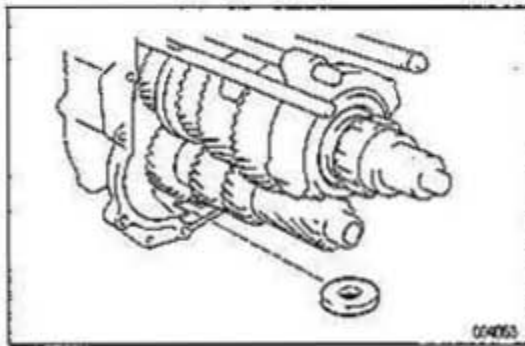

- 17. REMOVE MAGNET FROM INTERMEDIATE PLATE**

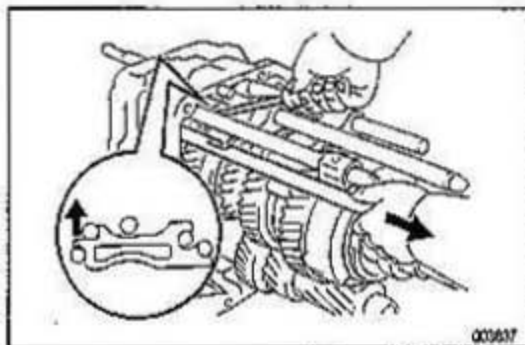

- 18. REMOVE SHIFT RAIL**
 Remove the shift rail while lifting the lock slider
 upward.

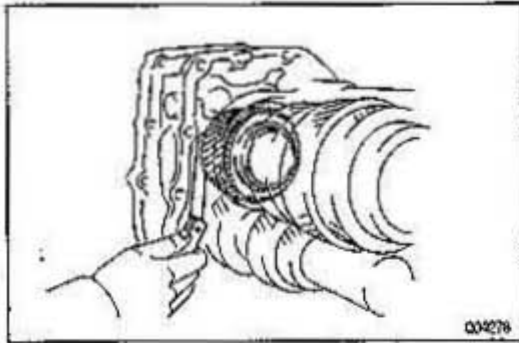
**19. MEASURE 4TH GEAR THRUST CLEARANCE**

Using a feeler gauge measure the 4th gear thrust clearance.

Maximum clearance:

0.26 mm (0.0102 in.)

If the clearance more than the limit, replace the gear.

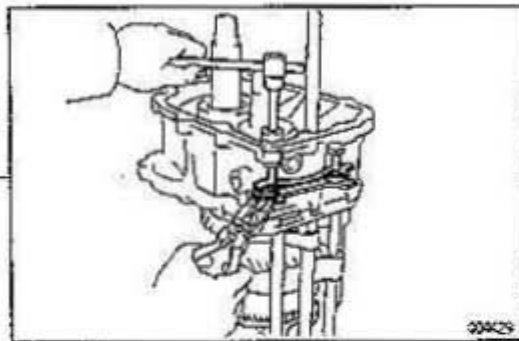
**20. REMOVE LOCK SLIDER SET BOLTS**

Hold the lock plate still with pliers while removing the 2 bolts.

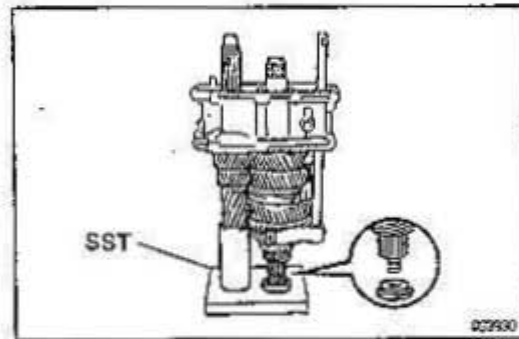
**21. REMOVE INTERMEDIATE PLATE**

(a) Stand the transmission upright on the SST so that the front of the transmission is facing upward.

SST 09310-14010

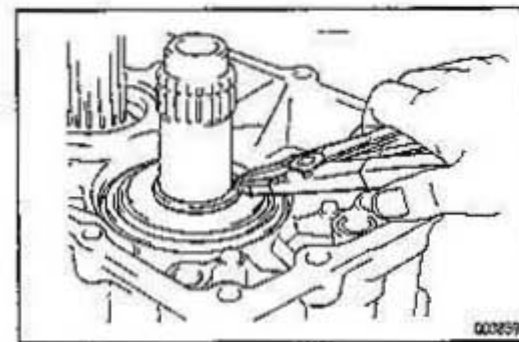

(b) Using a snap ring expander, remove the snap ring from the output shaft.

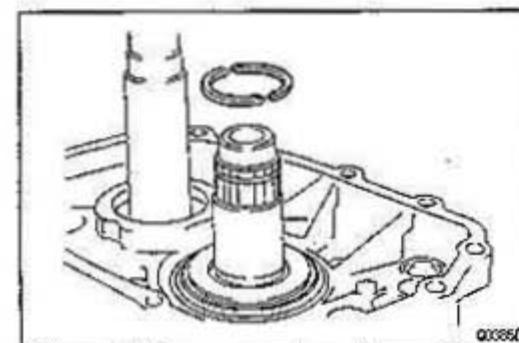

(c) Using a magnetic finger, remove the half shims.

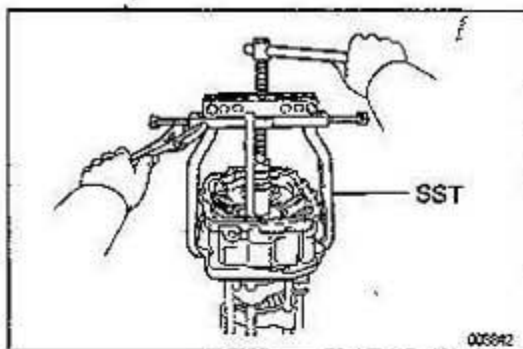

- (d) Using SST, remove the intermediate plate. SST 09950-20017
- (e) Remove the output shaft front bearing from the intermediate plate.
- (f) Remove the 1-2, 3-4, reverse shift fork, main control rod and lock slider from the output shaft.

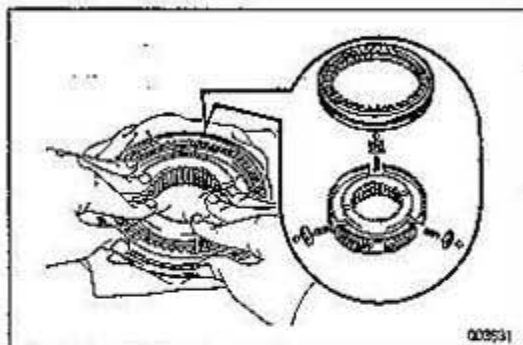

- 22. REMOVE 5 - 6 HUB SLEEVE, SHIFTING KEYS, BALLS AND SPRINGS FROM 5-6 CLUTCH HUB**
 Wrap the hub sleeve assembly in a shop rag to prevent it coming apart, then slide the sleeve upward to remove it, the 3 shifting keys, 3 balls and 3 springs.

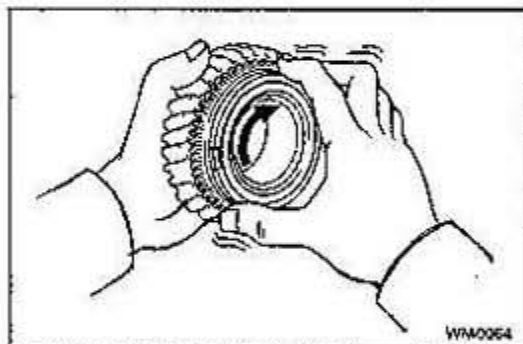

- 23. INSPECT 6TH GEAR SYNCHRONIZER RING**
- (a) Check for wear or damage.
 - (b) Check the braking effect of the synchronizer ring. Turn the synchronizer ring in one direction while pushing it to the gear cone. Check that the ring locks.

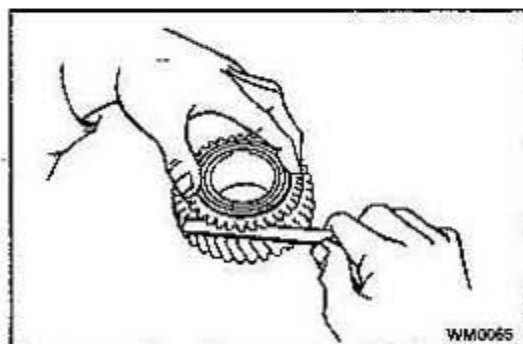

- (c) Using a feeler gauge, measure the clearance between the synchronizer ring back and gear spline end.
Minimum clearance:
 1.1 mm (0.043 in.)
 If the clearance is less than the limit, replace the synchronizer ring.

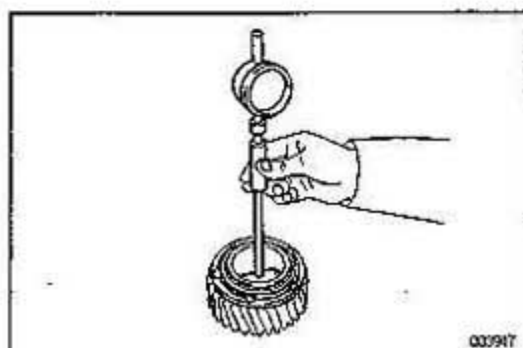

- 24. INSPECT 6TH GEAR INSIDE DIAMETER**
 Using a cylinder gauge, measure the inside diameter of 6th gear.
Maximum diameter:
 42.03 mm (1.6547 in.)
 If the inside diameter exceeds the maximum, replace the gear.

INPUT SHAFT COMPONENTS

M1277-01

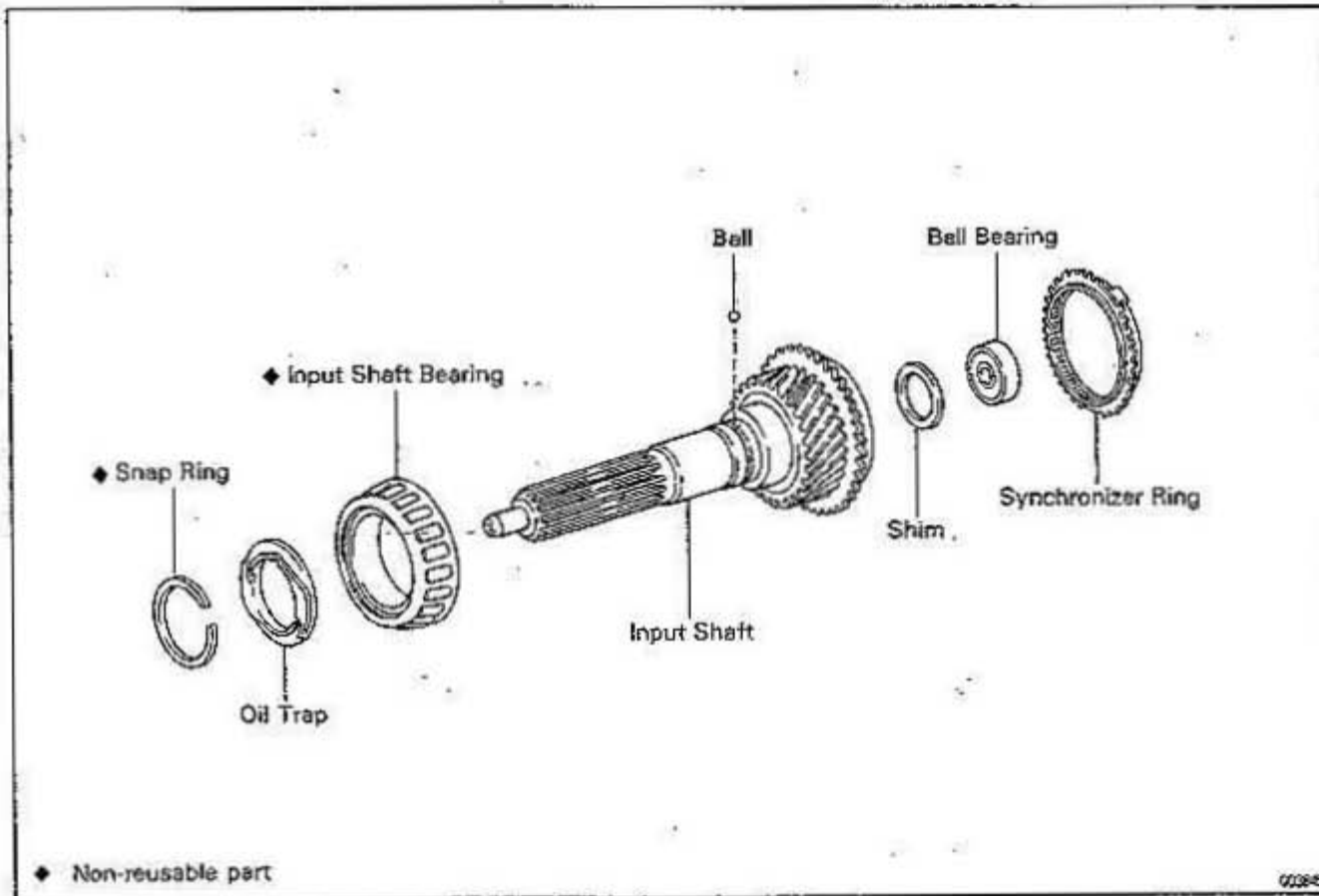

00385

M1277-01

INPUT SHAFT INSPECTION

1. INSPECT SYNCHRONIZER RING

- (a) Check for wear or damage.
- (b) Check the braking effect of the synchronizer ring. Turn the synchronizer ring in one direction while pushing it to the gear cone. Check that the ring locks.

- (c) Using a feeler gauge, measure the clearance between the synchronizer ring back and gear spline end.

Minimum clearance:

- 1.37 mm (0.0540 in.)

If the clearance is less than minimum, replace the synchronizer ring.

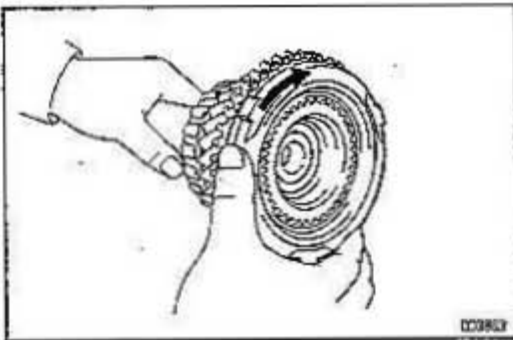

00385

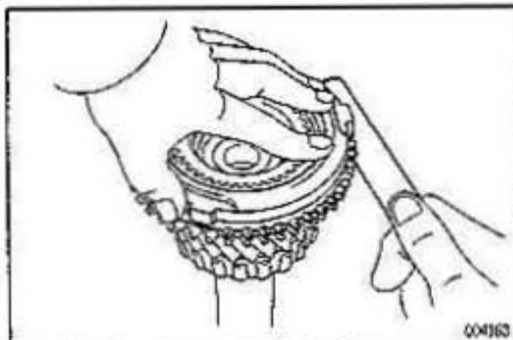

004163

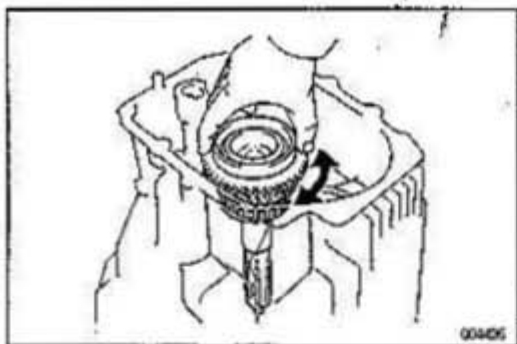

2. INSPECT TAPER ROLLER BEARING

Check that the taper roller bearing rotates smoothly with the input shaft installed in the front case.

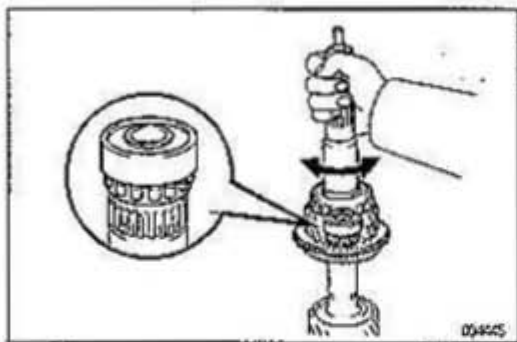

3. INSPECT BALL BEARING

Check that the ball bearing rotates smoothly with the input shaft installed in the output shaft.

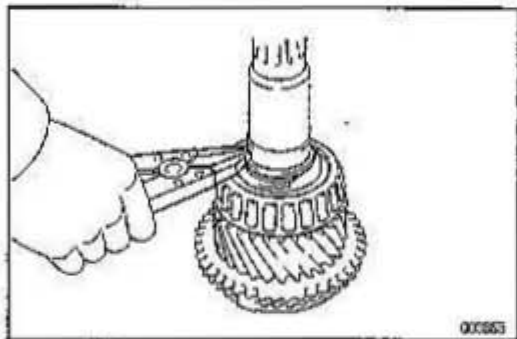

BEARING REPLACEMENT

MT21-01

1. REPLACE INPUT SHAFT BEARING

(a) Using a snap ring expander, remove the snap ring.
NOTICE: Take care to not scratch the input shaft.

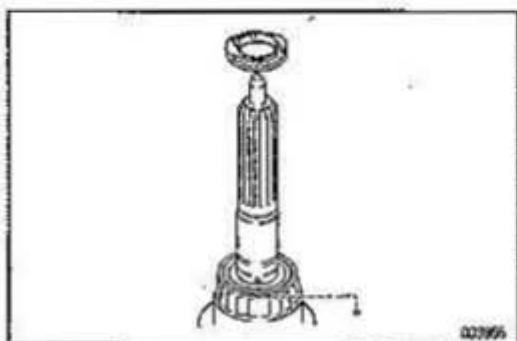

(b) Remove the oil trap and ball from the input shaft.

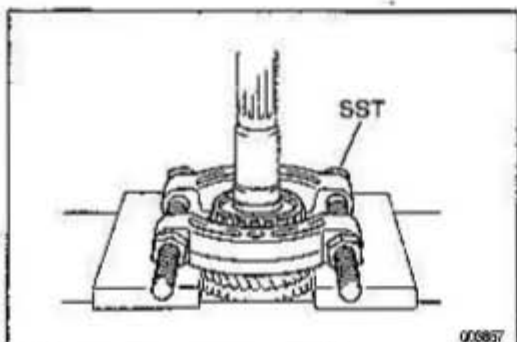

(c) Using SST and a press, remove the input shaft bearing.
 SST 09950-00020

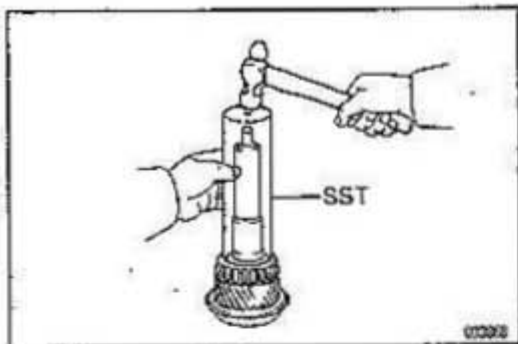

- (d) Heat a new bearing in an oven.
[100 – 110°C (212 – 230°F)]
CAUTION: Take care to avoid burns.
- (e) Apply gear oil to the input shaft and install the bearing.
- (f) Using SST and a hammer, tap the bearing.
SST 09308-14010
NOTICE: Perform the remaining steps after the bearing has returned to normal temperature.

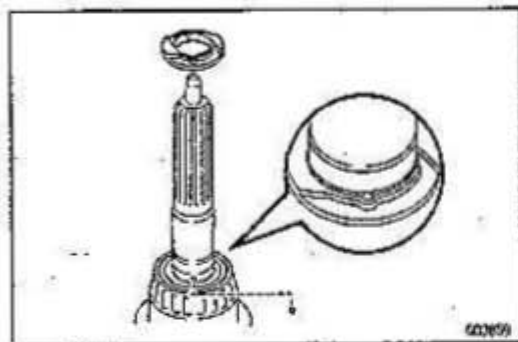

- (g) Install the ball and oil trap to the input shaft.
NOTICE: Do not install the ball in the oil hole by mistake.

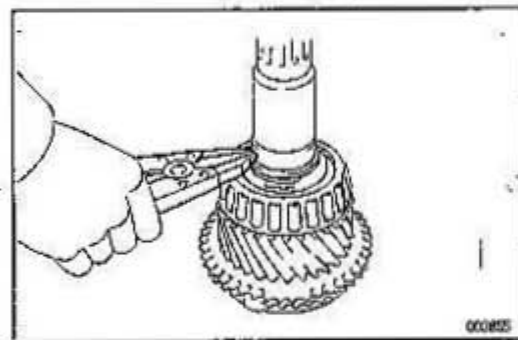

- (h) Using a snap ring expander, install a new snap ring.
NOTICE:
- Do not expand the snap ring more than is necessary.
 - Take care to not scratch the input shaft.

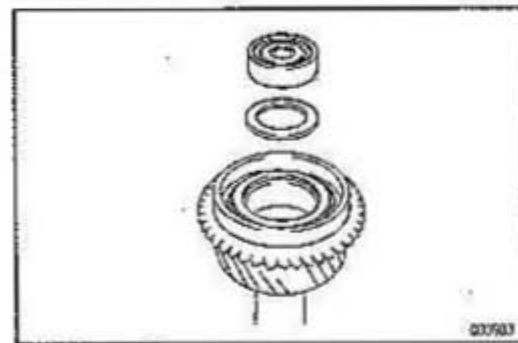

2. REPLACE BALL BEARING

- (a) Remove the ball bearing and adjusting shim from the input shaft.

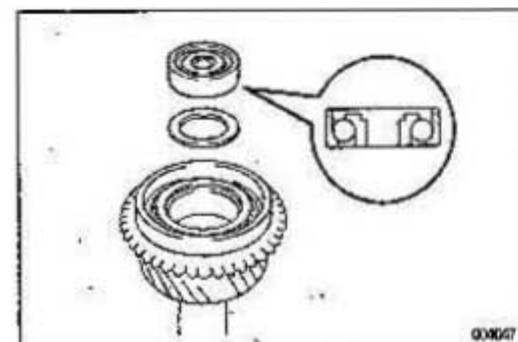

- (b) Apply MP grease to a new ball bearing.
- (c) Install a minimum thickness shim and ball bearing to the input shaft.

OUTPUT SHAFT COMPONENTS

MT23-01

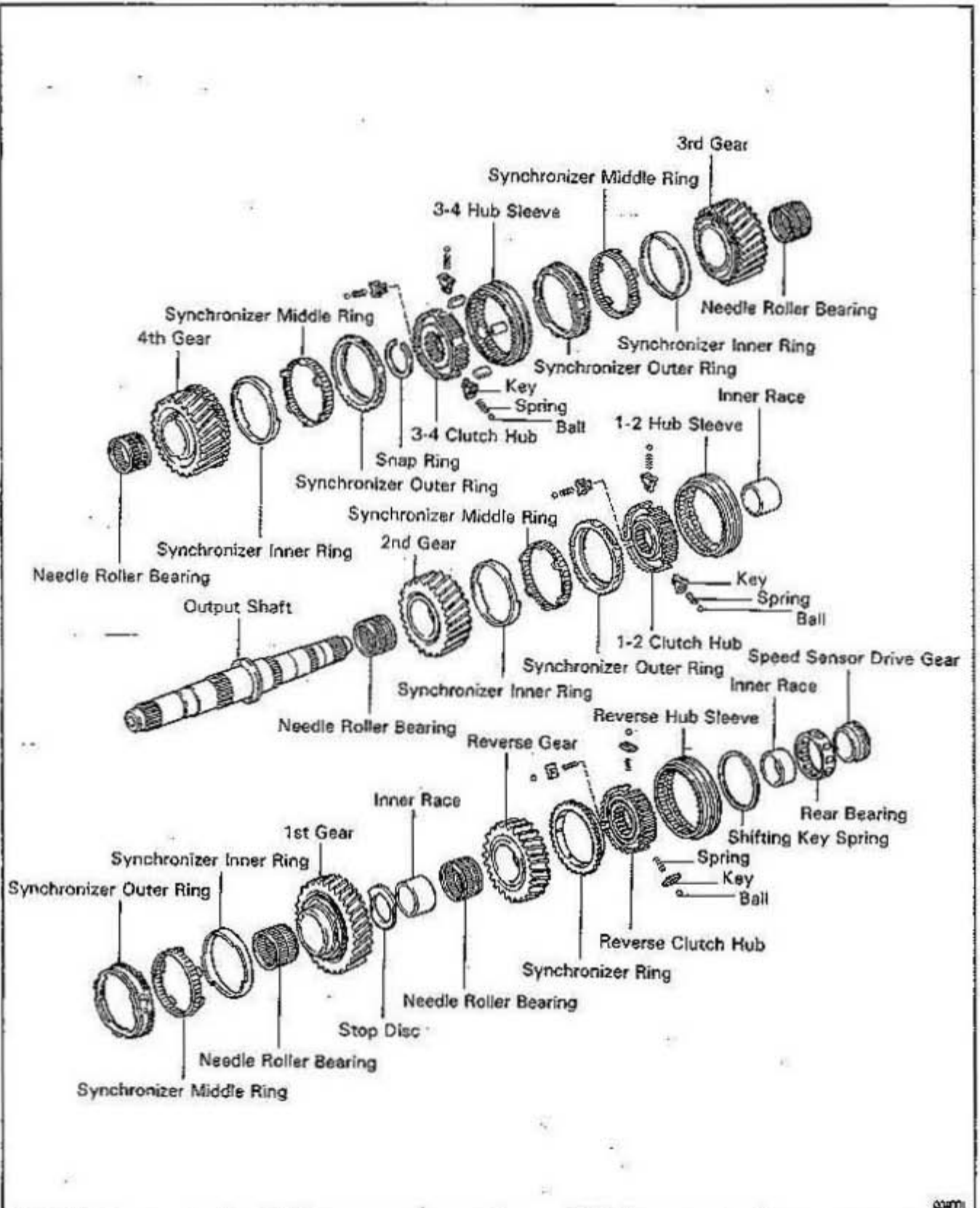

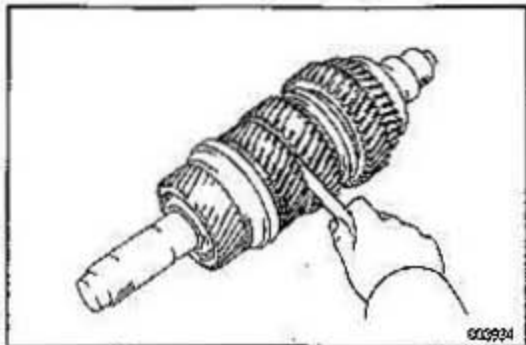
OUTPUT SHAFT DISASSEMBLY**1. MEASURE EACH GEAR THRUST CLEARANCE**

Using a feeler gauge, measure the thrust clearance of each gear.

Maximum clearance:

1st and 2nd gear

0.26 mm (0.0102 in.)

3rd and Reverse gear

0.18 mm (0.0071 in.)

If the clearance more than the limit, replace the gear.

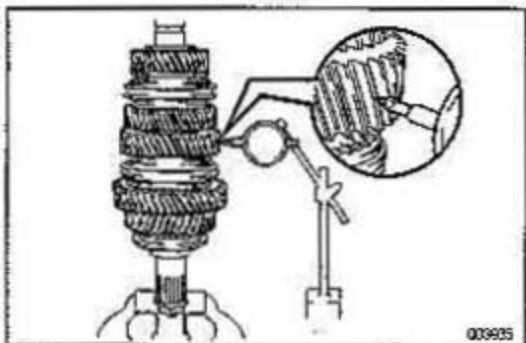
**2. MEASURE EACH GEAR RADIAL CLEARANCE**

Using a dial indicator, measure each gear radial clearance.

Maximum clearance:

1st gear

0.09 mm (0.0035 in.)

2nd gear

0.06 mm (0.0024 in.)

3rd and 4th gear

0.05 mm (0.0020 in.)

Reverse gear

0.08 mm (0.0031 in.)

If the clearance is more than the limit, replace the gear, needle roller bearing or shaft.

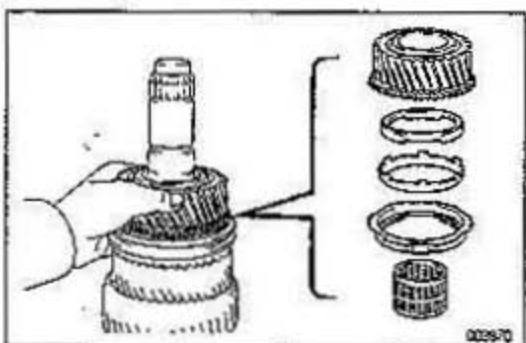
**3. REMOVE 4TH GEAR, SYNCHRONIZER RINGS AND NEEDLE ROLLER BEARING**

NOTICE: Label the synchronizer ring so that you can identify it.

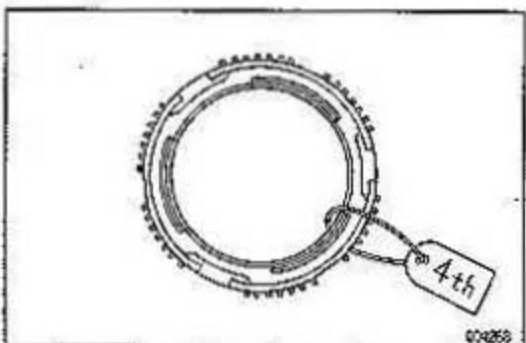
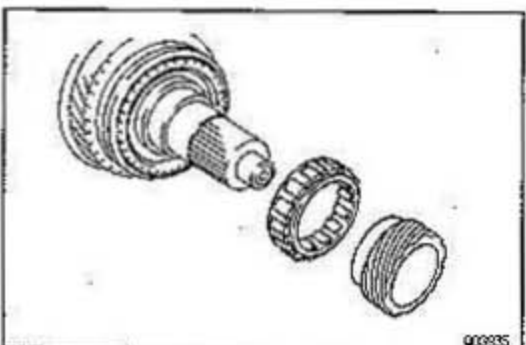
**4. REMOVE SPEED SENSOR DRIVE GEAR AND OUTPUT SHAFT REAR BEARING**

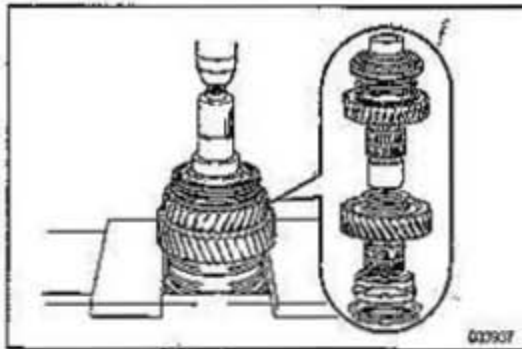

5. REMOVE REVERSE HUB SLEEVE, REVERSE GEAR AND 1ST GEAR

Using a press, remove the following parts.

- Rear bearing inner race
- Reverse hub sleeve
- Synchronizer ring (for reverse gear)
- Reverse gear
- Needle roller bearing (for reverse gear)
- Bearing inner race (for reverse gear)
- Stop disc
- 1st gear
- Needle roller bearing (for 1st gear)
- Synchronizer rings (for 1st gear)

NOTICE: Label the synchronizer ring so that you can identify it.

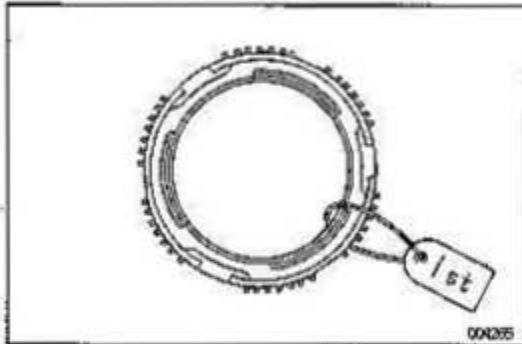

6. REMOVE 1-2 HUB SLEEVE AND 2ND GEAR

Using a press, remove the following parts.

- Bearing inner race (for 1st gear)
- 1-2 hub sleeve
- Synchronizer rings (for 2nd gear)
- 2nd gear
- Needle roller bearing (for 2nd gear)

NOTICE: Label the synchronizer ring so that you can identify it.

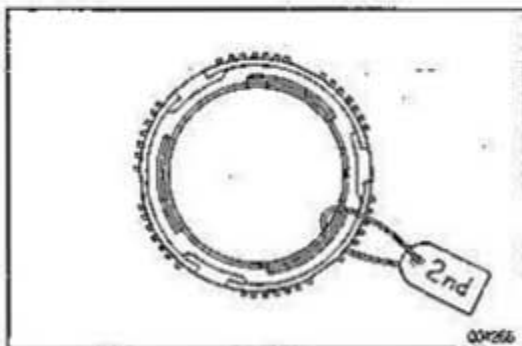
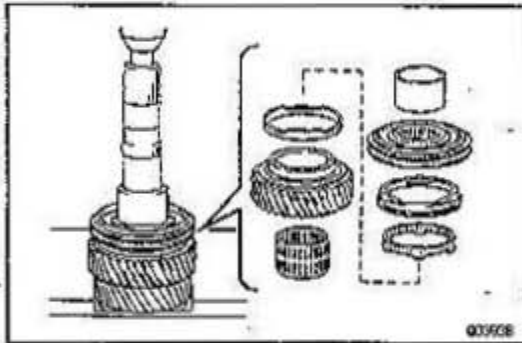

7. REMOVE 3-4 HUB SLEEVE AND 3RD GEAR

- (a) Using a snap ring expander, remove the snap ring.

NOTICE: Take care to not scratch the output shaft.

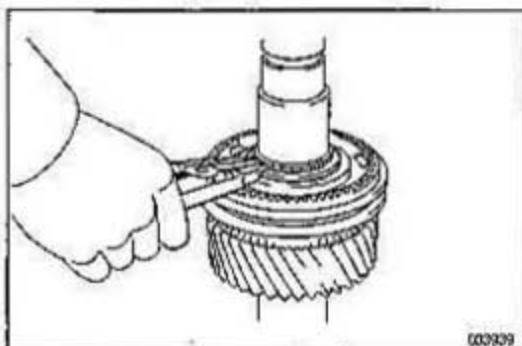

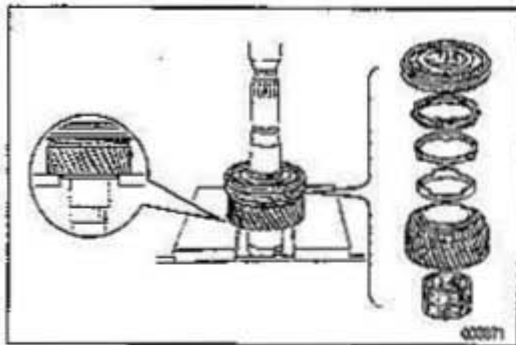

(b) Using a press, remove the following parts.

- 3-4 hub sleeve
- Synchronizer rings (for 3rd gear)
- 3rd gear
- Needle roller bearing (for 3rd gear)

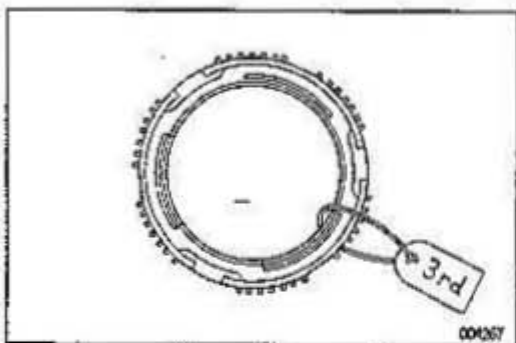

NOTICE: Label the synchronizer ring so that you can identify it.

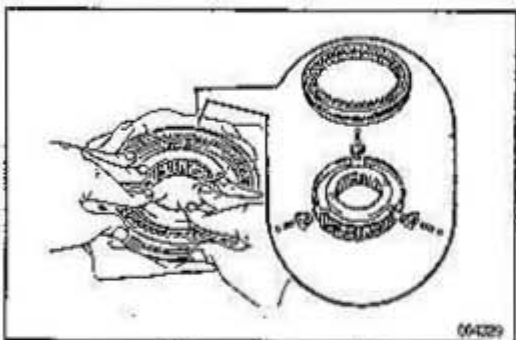

8. DISASSEMBLE EACH HUB SLEEVES

1-2 hub sleeve:

Wrap the 1-2 hub sleeve assembly in a shop rag to prevent it coming apart; then slide the sleeve upward to remove it, the 3 shifting keys, 3 balls and 3 springs.

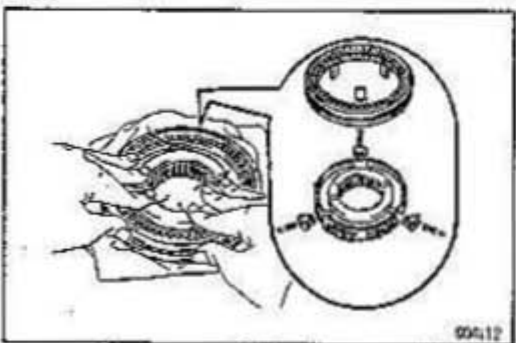

3-4 hub sleeve:

Wrap the 3-4 hub sleeve assembly in a shop rag to prevent it coming apart; then slide the sleeve upward to remove it, the 3 plates, 3 shifting keys, 3 balls, and 3 springs.

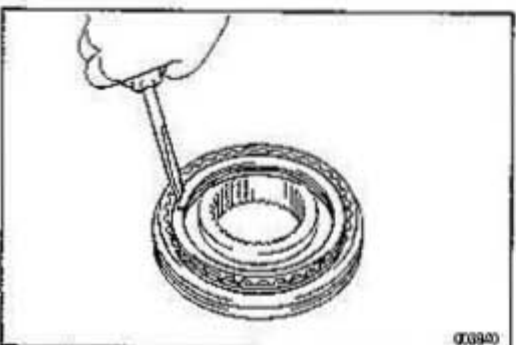

Reverse hub sleeve:

(a) Using a screwdriver, remove the snap ring.

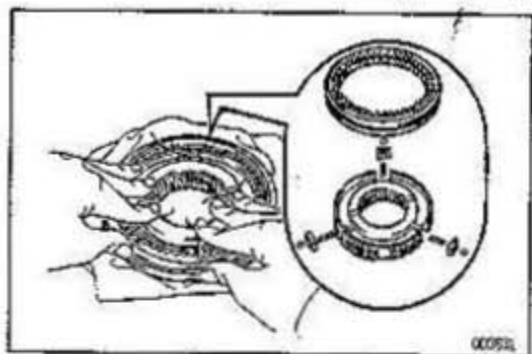

- (b) Wrap the reverse hub sleeve assembly in a shop rag to prevent it coming apart, then slide the sleeve upward to remove it, the 3 shifting keys, 3 balls and 3 springs.

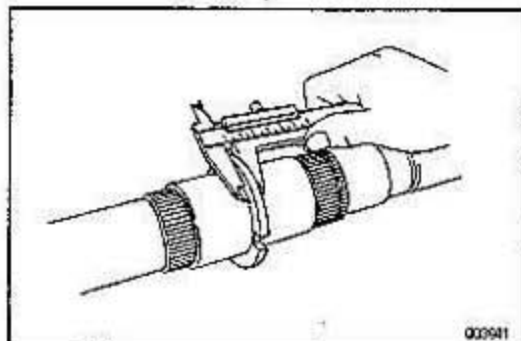

003941

OUTPUT SHAFT COMPONENT PARTS INSPECTION

1. INSPECT OUTPUT SHAFT

- (a) Using a caliper gauge, measure the output shaft flange thickness.

Minimum thickness:

5.2 mm (0.205 in.)

If the thickness exceeds the minimum, replace the output shaft.

- (b) Using a micrometer, measure the outer diameter of the output shaft journal.

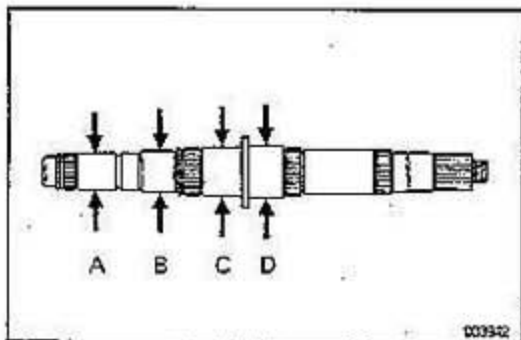

003942

Part	Minimum diameter mm (in.)
A	36.99 (1.4563)
B	41.99 (1.6531)
C	49.99 (1.9681)
D	52.99 (2.0862)

If the outer diameter is less than minimum, replace the output shaft.

- (c) Using a micrometer, measure the outer diameter of the inner race.

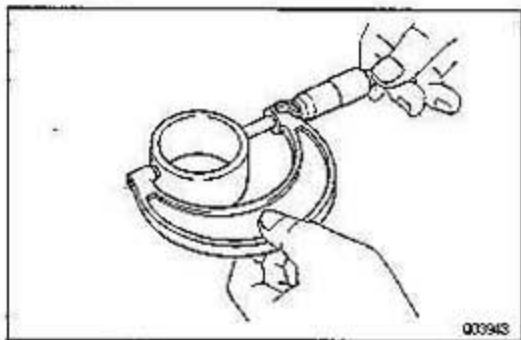

003943

Part	Minimum diameter mm (in.)
1st gear	52.95 (2.0845)
Reverse gear	52.95 (2.0846)
Rear bearing	47.96 (1.8882)

If the outer diameter is less than minimum, replace the inner race.

- (d) Using a dial indicator, check the shaft runout.

Maximum runout:

0.05 mm (0.0020 in.)

If the runout exceeds the maximum, replace the output shaft.

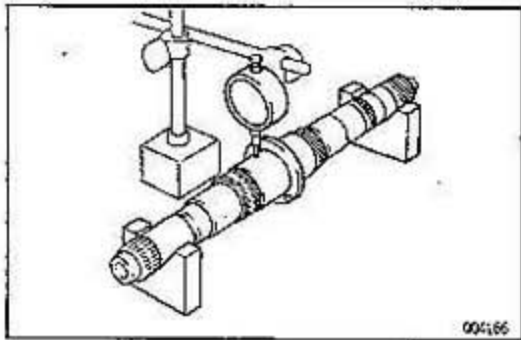

004166

2. INSPECT SYNCHRONIZER RINGS

- (a) Check for wear or damage.
- (b) Check the braking effort of the synchronizer ring. Turn the synchronizer ring in one direction while pushing it to the gear cone. Check that the ring locks. If it does not lock replace synchronizer rings.

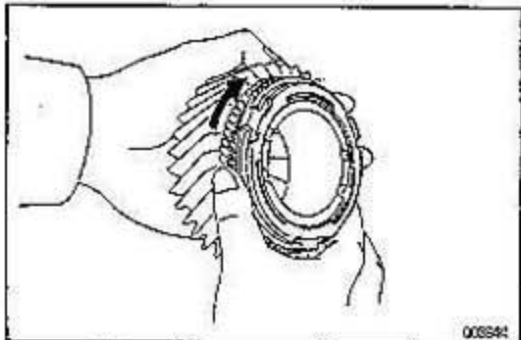

003944

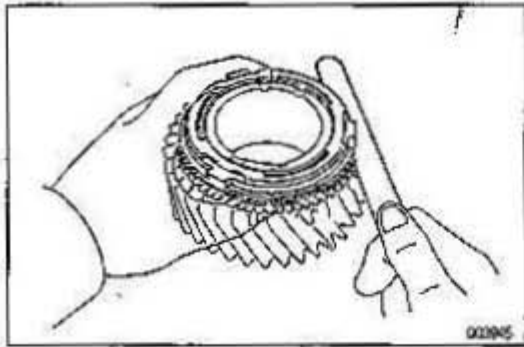

- (c) Using a feeler gauge, measure the clearance between the synchronizer ring back and gear spline end.

Minimum clearance:

1.1 mm (0.043 in.)

If the clearance is less than the limit, replace the synchronizer ring.

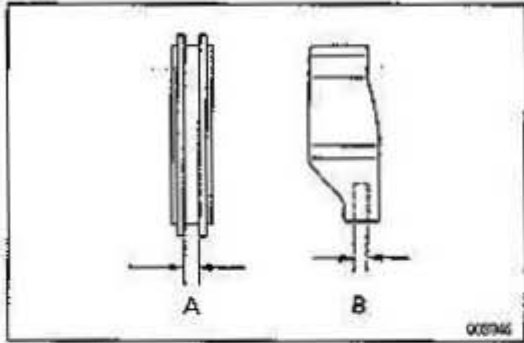

3. INSPECT CLEARANCE OF SHIFT FORKS AND HUB SLEEVES

Using a caliper gauge, measure the clearance between the hub sleeve and shift fork.

Standard wide:

Reverse gear

A 5.45–5.55 mm (0.2146–0.2185 in.)

B 5.37–5.40 mm (0.2114–0.2126 in.)

Others

A 7.05–7.15 mm (0.2776–0.2815 in.)

B 6.96–7.00 mm (0.2740–0.2756 in.)

Maximum clearance:

0.7 mm (0.028 in.)

If the clearance exceeds the limit, replace the shift fork or hub sleeve.

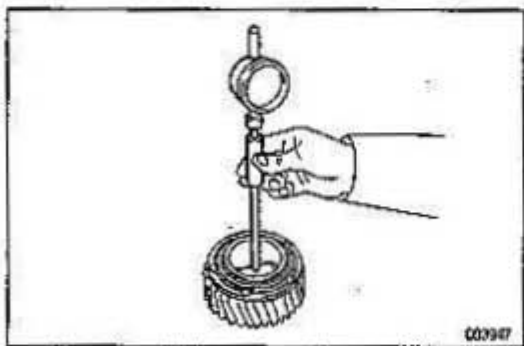

4. INSPECT EACH GEAR INSIDE DIAMETER

Using a cylinder gauge, measure the inside diameter of each gear.

Gear	Maximum diameter mm (in.)
1st	58.03 (2.2846)
2nd	58.03 (2.2846)
3rd	55.03 (2.1665)
4th	47.00 (1.8504)
Reverse	58.03 (2.2846)

If the inside diameter exceeds the maximum, replace the gear.

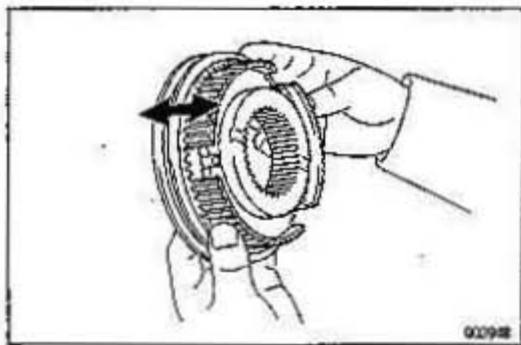

5. INSPECT HUB SLEEVE AND CLUTCH HUB

Check that the hub sleeve and clutch hub slide smoothly.

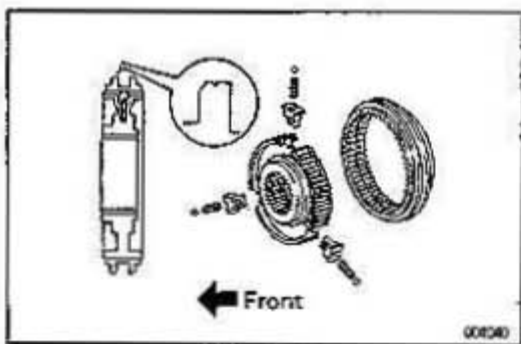

OUTPUT SHAFT ASSEMBLY

(See page MT-23)

HINT: Coat all of the sliding and rotating surface with gear oil before assembly.

1. ASSEMBLE EACH HUB SLEEVES

1-2 hub sleeve:

Assemble the clutch hub, hub sleeve, 3 shifting keys, 3 balls and 3 shifting key springs.

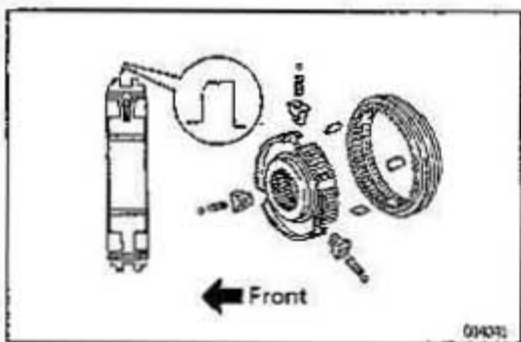

3-4 hub sleeve:

Assemble the clutch hub, hub sleeve, 3 shifting keys, 3 balls and 3 plates and 3 shifting key springs.

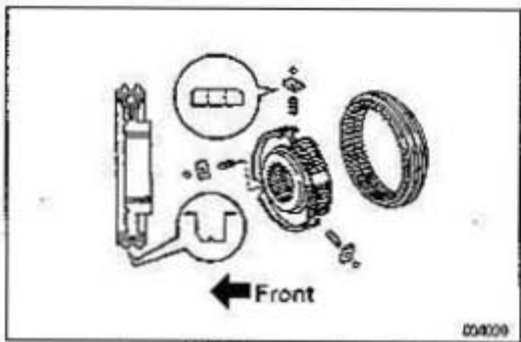

Reverse hub sleeve:

- (a) Assemble the clutch hub, hub sleeve, 3 shifting keys, 3 balls and 3 shifting key springs.

NOTICE: Install the shifting keys with the bevelled edges facing outward.

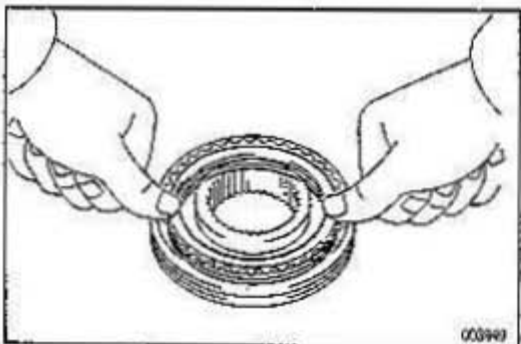

- (b) Install the snap ring to the clutch hub.

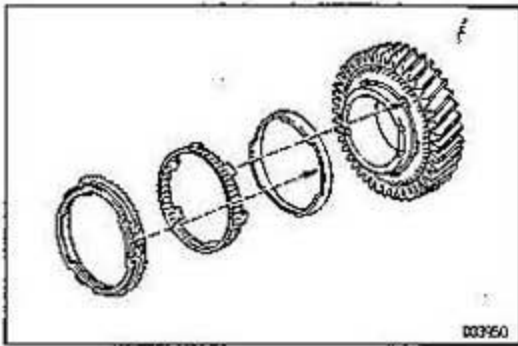
**2. INSTALL 2ND GEAR**

- (a) Apply gear oil to the synchronizer rings.
- (b) Install the synchronizer rings to the gear with the tabs aligned as shown here.

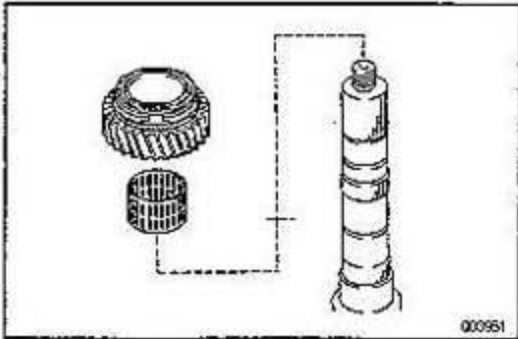

- (c) Apply gear oil to the shaft and needle roller bearing.
- (d) Install the needle roller bearing and 2nd gear to the output shaft.

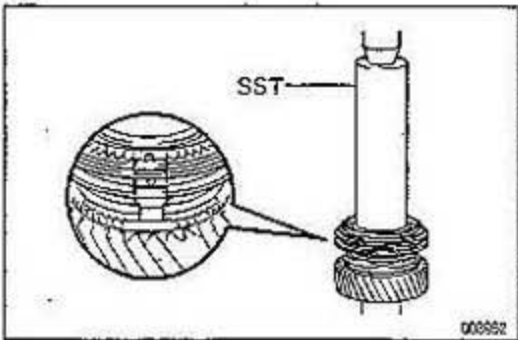
**3. INSTALL 1-2 HUB SLEEVE**

Using SST and a press, install the 1-2 hub sleeve.
SST 09308-14010

NOTICE: Align the synchronizer ring tab with the groove in the clutch hub.

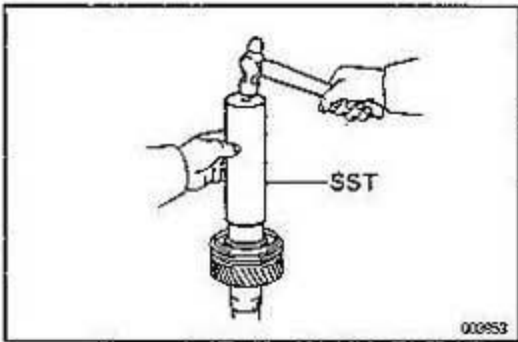
**4. INSTALL 1ST GEAR**

- (a) Heat the 1st gear inner race in an oven.
[100-110°C (212-230°F)]
CAUTION: Take care to avoid burns.
- (b) Apply gear oil to the output shaft and install the inner race.
HINT: Rotate the inner race as you install it.
- (c) Using SST and a hammer, tap the inner race.
SST 09308-14010
NOTICE: Perform the remaining steps after the inner race has returned to normal temperature.
- (d) Apply gear oil to the synchronizer rings.
- (e) Install the synchronizer rings to the gear with the tabs aligned as shown here.

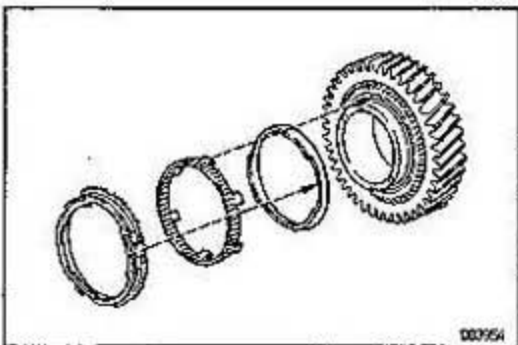

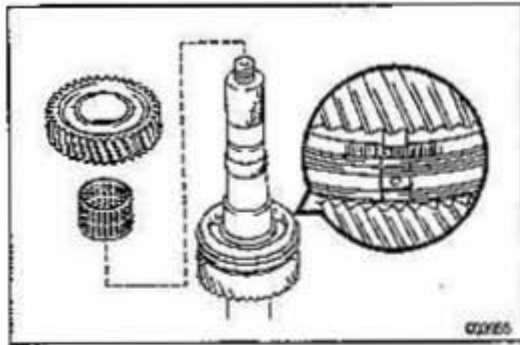

- (f) Apply gear oil to the needle roller bearing.
 (g) Install the needle roller bearing and 1st gear to the output shaft.
NOTICE: Align the synchronizer ring tab with the groove in the clutch hub.

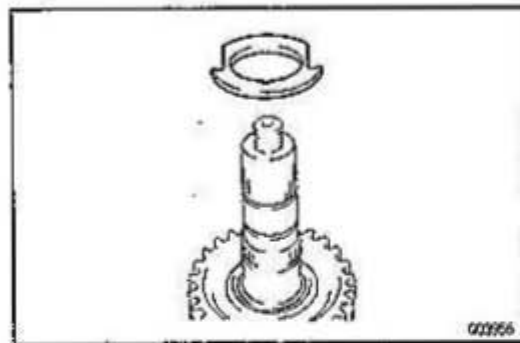

5. INSTALL STOP DISC

Apply gear oil to the stop disc and install it to the output shaft.

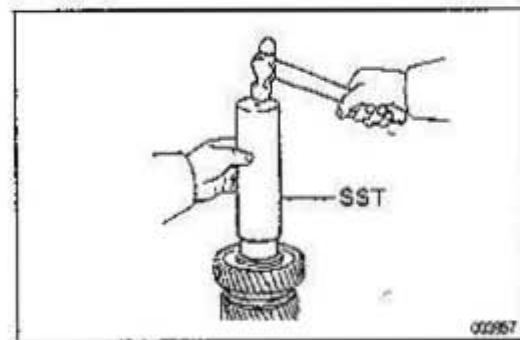

6. INSTALL REVERSE GEAR

- (a) Heat the reverse gear inner race in an oven.
 [100 – 110°C (212 – 230°F)]
CAUTION: Take care to avoid burns.
 (b) Apply gear oil to the output shaft and install the inner race.
HINT: Rotate the inner race as you install it.
 (c) Using SST and a hammer tap the inner race.
 SST 09308 – 14010
NOTICE: Perform the remaining steps after the inner race has returned to normal temperature.
 (d) Apply gear oil to the synchronizer ring and place it on the gear.
 (e) Apply gear oil to the needle roller bearing.
 (f) Install the needle roller bearing and reverse gear to the output shaft.

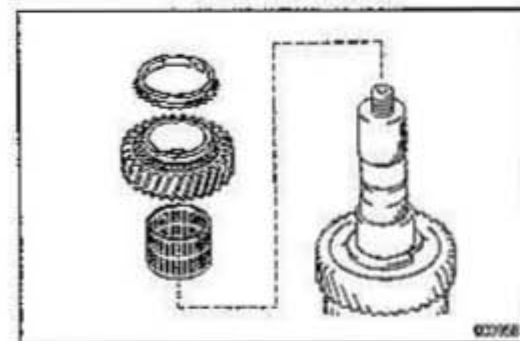

7. INSTALL REVERSE HUB SLEEVE

Using SST and a press, install the reverse hub sleeve.
 SST 09308 – 14010
NOTICE: Align the synchronizer ring tab with the groove in the clutch hub.

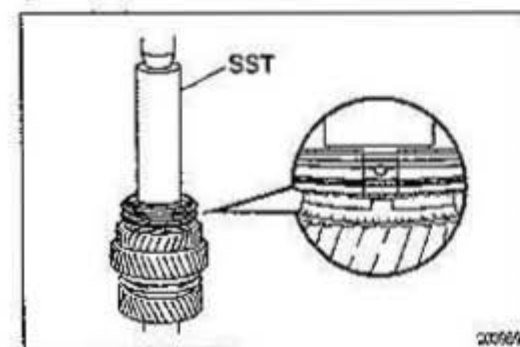

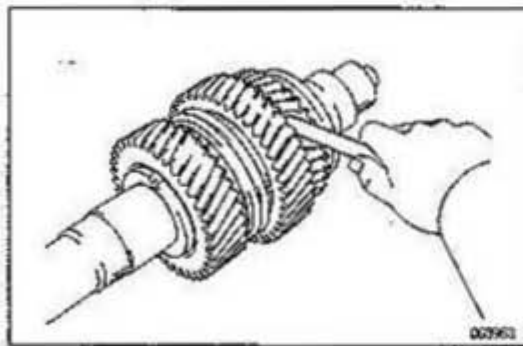
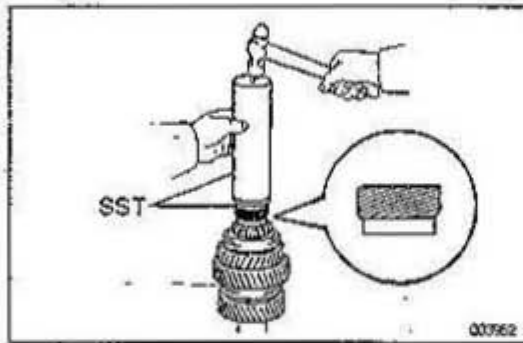
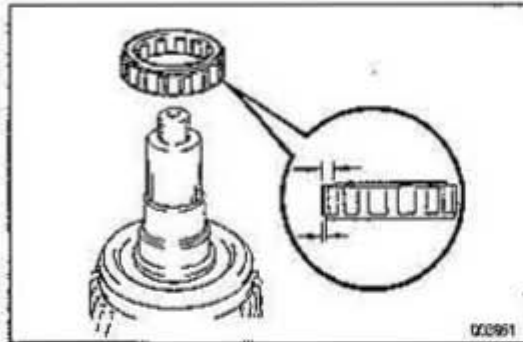
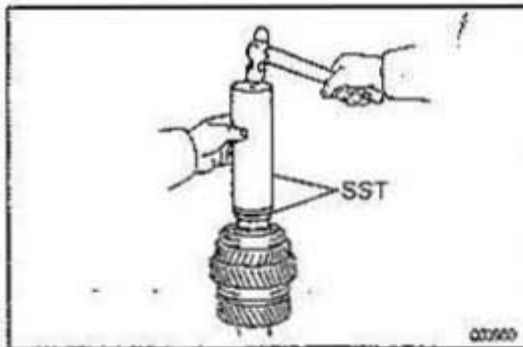

8. INSTALL OUTPUT SHAFT REAR BEARING

- (a) Heat the rear bearing inner race in an oven. [100 — 110°C (212 — 230°F)]
CAUTION: Take care to avoid burn.
- (b) Apply gear oil to the output shaft and install the inner race.
HINT: Rotate the inner race as you install it.
- (c) Using SST and a hammer, tap the inner race.
SST 09308—14010, 09309—14020
NOTICE: Perform the remaining steps after the inner race has returned to normal temperature.
- (d) Install the rear bearing.
NOTICE: Install the bearing with the wider race upward.

9. INSTALL SPEED SENSOR DRIVE GEAR

- (a) Apply gear oil to the output shaft and install the drive gear.
HINT: If necessary, heat the drive gear in an oven. [100 — 110°C (212 — 230°F)]
- (b) Using SST and a hammer, tap the drive gear.
SST 09308—14010, 09309—14020

10. INSPECT 1ST, 2ND AND REVERSE GEAR THRUST CLEARANCE

Using a feeler gauge, measure the 1st, 2nd and reverse gear thrust clearance.

Maximum clearance:

- 1st gear
0.09 mm (0.0035 in.)
- 2nd gear
0.06 mm (0.0024 in.)
- Reverse gear
0.08 mm (0.0031 in.)

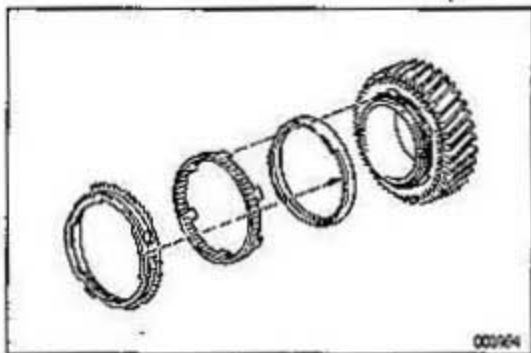
**11. INSTALL 3RD GEAR**

- (a) Apply gear oil to the synchronizer rings.
 (b) Install the synchronizer rings to the gear with the tabs aligned as shown here.

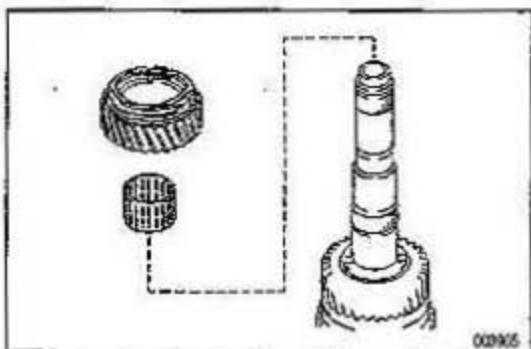

- (c) Apply gear oil to the needle roller bearing.
 (d) Install the needle roller bearing and 3rd gear to the output shaft.

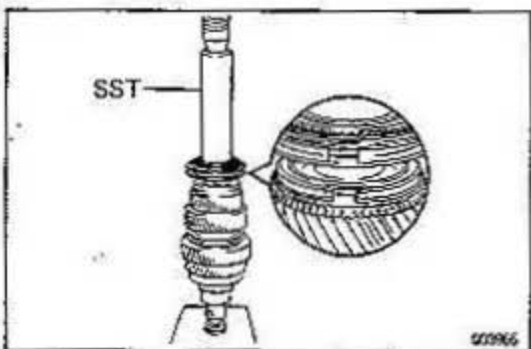
**12. INSTALL 3-4 HUB SLEEVE**

- (a) Using SST and a press, install the 3-4 hub sleeve.
 SST 09308-14010
NOTICE: Align the synchronizer ring tab with the groove in the clutch hub.

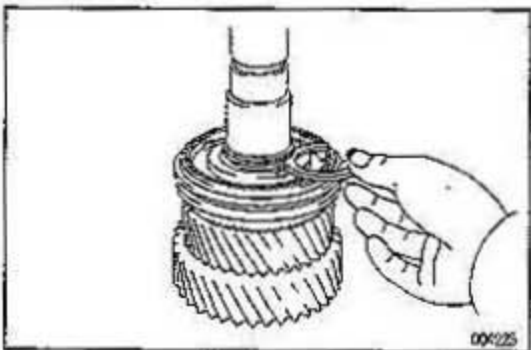

- (b) Select a new snap ring that will allow minimum axial play.

Snap ring thickness mm (in.)	Snap ring thickness mm (in.)
2.01-2.05 (0.0791-0.0807)	1.86-1.90 (0.0733-0.0748)
1.96-2.00 (0.0772-0.0787)	1.81-1.85 (0.0713-0.0729)
1.91-1.95 (0.0752-0.0768)	1.76-1.80 (0.0693-0.0709)

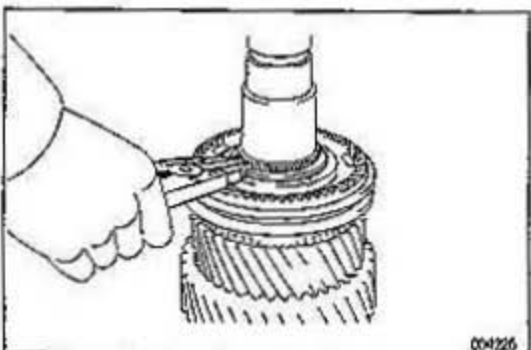

- (c) Using a snap ring expander, install the snap ring.
NOTICE:

- Do not expand the snap ring more than is necessary.
- Take care to not scratch the output shaft.

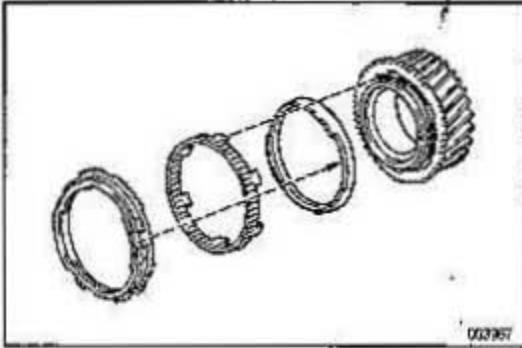
**13. INSTALL 4TH GEAR**

- (a) Apply gear oil to the synchronizer ring.
- (b) Install the synchronizer rings to the gear with the tabs aligned as shown here.

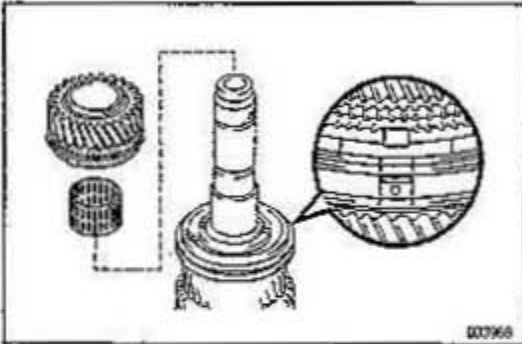

- (c) Apply gear oil to the needle roller bearing.
- (d) Install the needle roller bearing and 4th gear to the output shaft.

NOTICE: Align the synchronizer ring tab with the groove in the clutch hub.

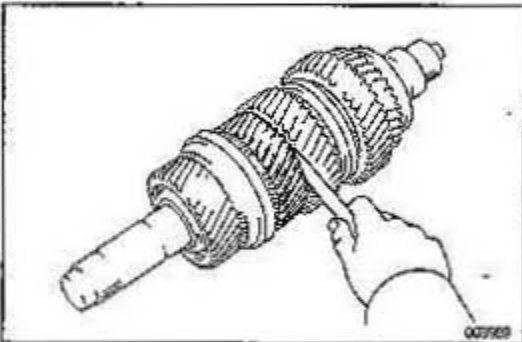
**14. INSPECT 3RD GEAR THRUST CLEARANCE**

Using a feeler gauge, measure the 3rd gear thrust clearance.

Maximum clearance:

0.05 mm (0.0020 in.)

COUNTER GEAR COMPONENTS

MT086-01

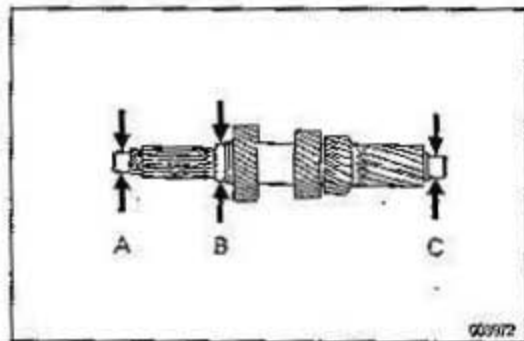
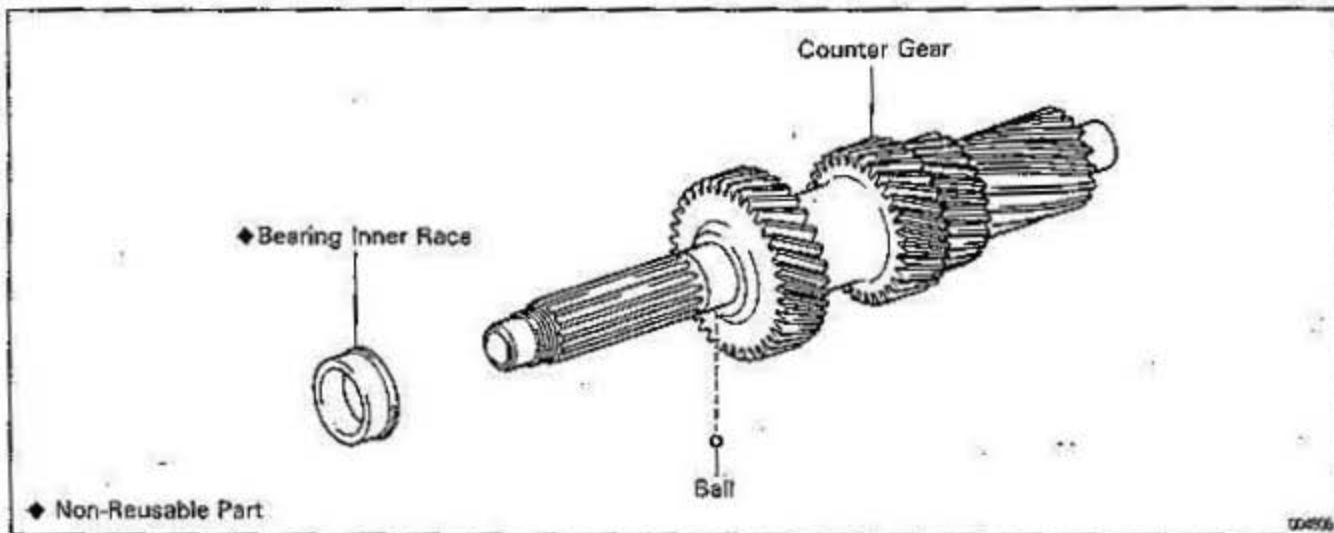

COUNTER GEAR INSPECTION

MT086-01

INSPECT COUNTER GEAR AND INNER RACE

Using a micrometer, measure the outer diameter of the counter gear and inner race journal.

Part	Minimum diameter mm (in.)
A	26.01 (1.0240)
B	36.00 (1.3778)
C	26.01 (1.0240)

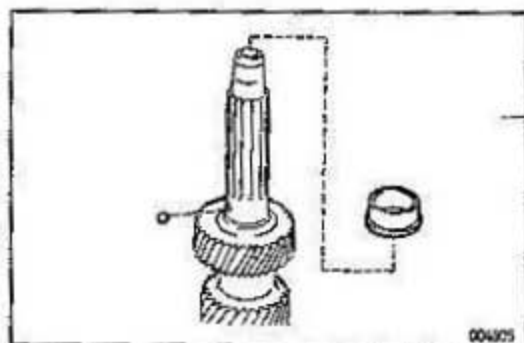

INNER RACE REPLACEMENT

MT086-01

REPLACE BEARING INNER RACE

- Remove the bearing inner race and ball.
- Apply gear oil to a new bearing inner race.
- Install the ball and inner race to the counter gear.

FRONT CASE COMPONENTS

MT042-01

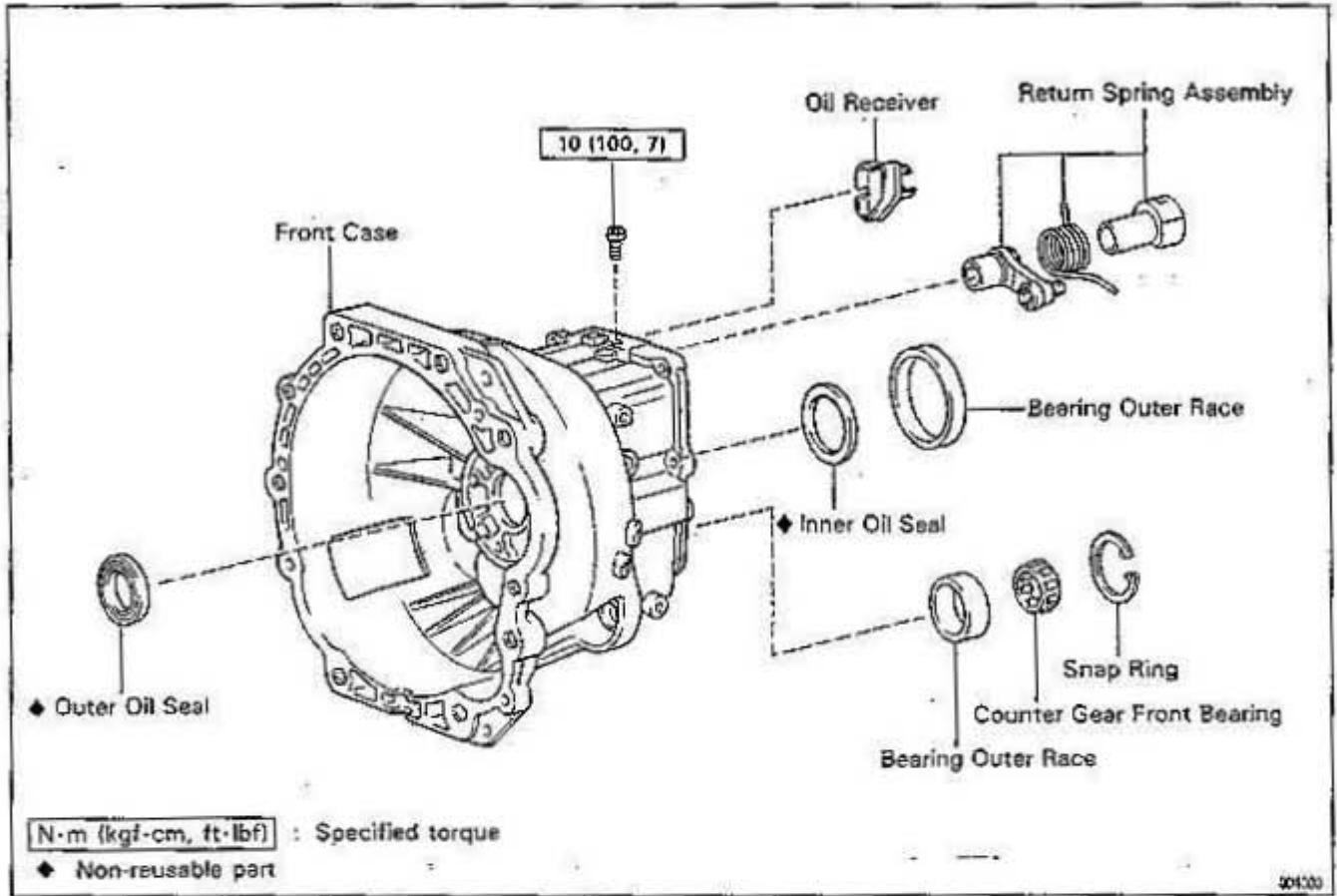

FRONT CASE DISASSEMBLY

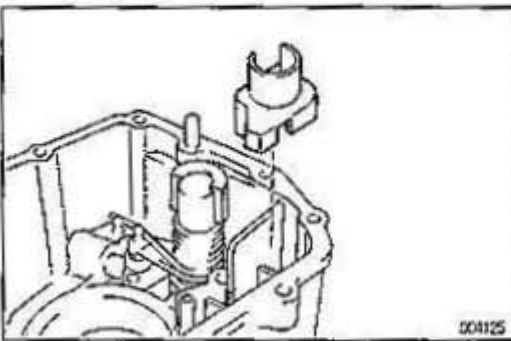

1. REMOVE OIL RECEIVER

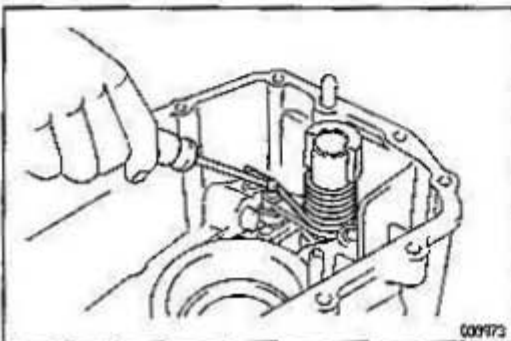

2. REMOVE RETURN SPRING ASSEMBLY

(a) Using a screwdriver, lift up the end of spring.

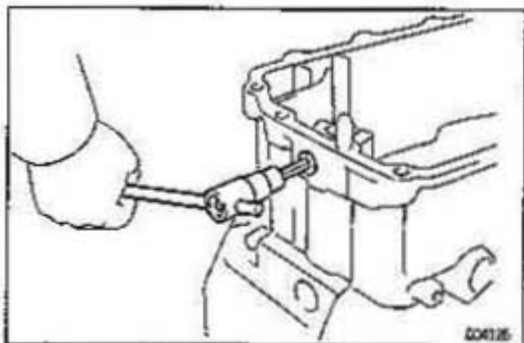

(b) Using a hexagon wrench, remove the bolt.

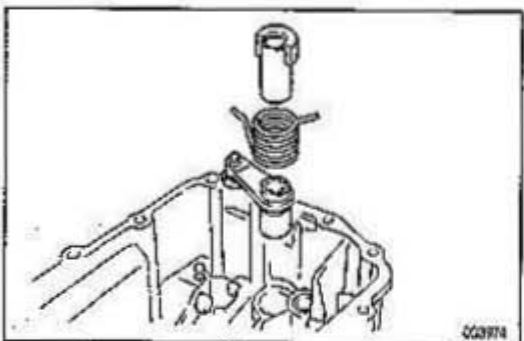

(c) Remove the return spring assembly.

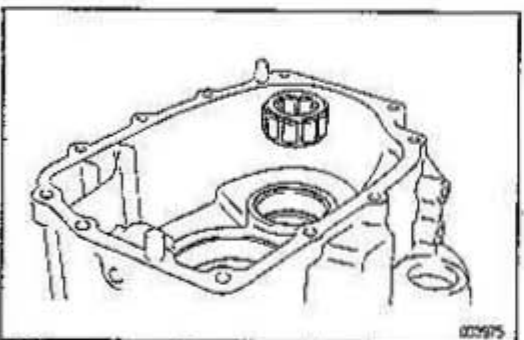

3. REMOVE COUNTER GEAR FRONT BEARING

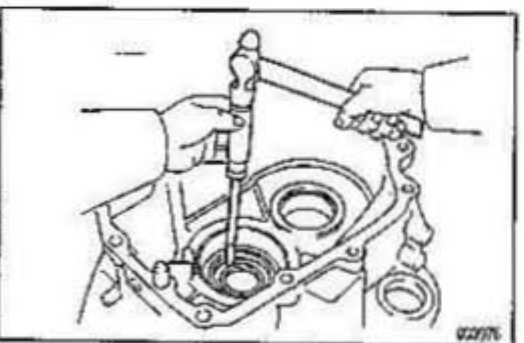

FRONT CASE COMPONENT PARTS REPLACEMENT

1. REPLACE INPUT SHAFT OIL SEAL AND BEARING OUTER RACE

(a) Using a screwdriver and hammer, drive out the outer oil seal.

(b) Heat the front case in boiling water.
[80 – 90°C (176 – 194°F)]

(c) Remove the input shaft bearing outer race.

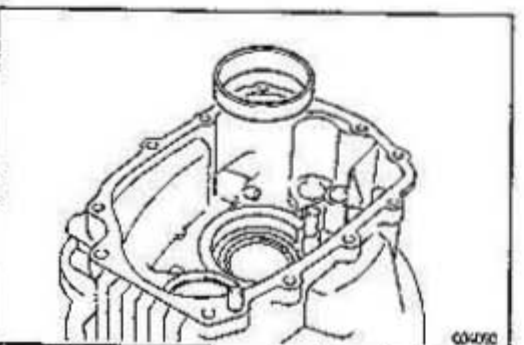

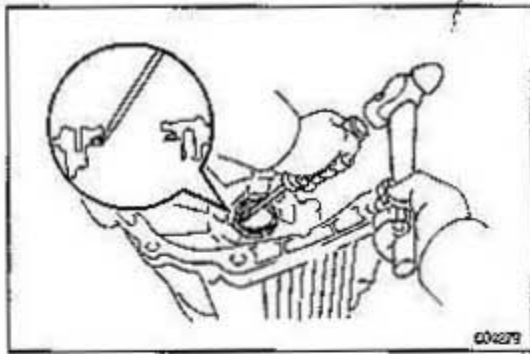

- (d) Using a screwdriver and hammer, drive out the inner oil seal.

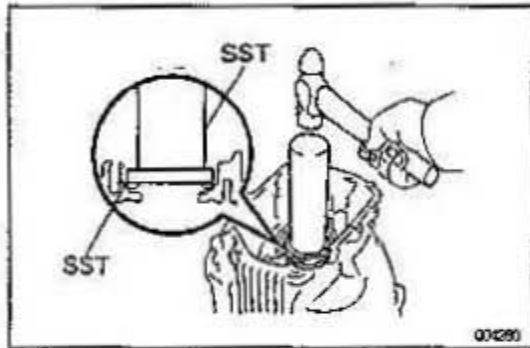

- (e) Using SST and a hammer, install a new inner oil seal.
SST 09308-14010, 09309-14040

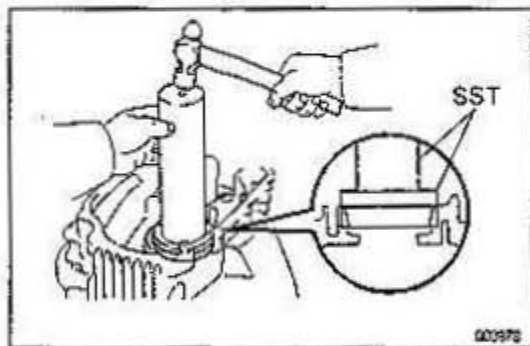

- (f) Heat the front case in boiling water.
[80 – 90°C (176 – 194°F)]
(g) Apply gear oil to a new outer race and install it to the front case.
(h) Using SST and a hammer, tap the bearing outer race.
SST 09308-14010, 09309-14050

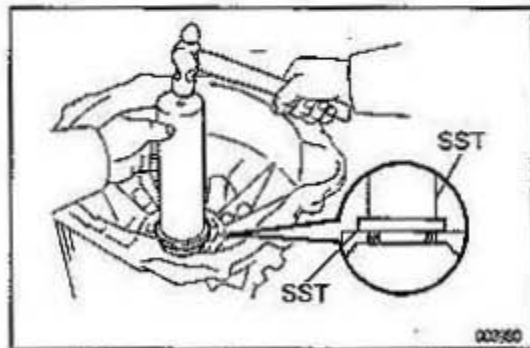

- (i) Using SST and a hammer, install a new outer oil seal.
SST 09308-14010, 09309-14040

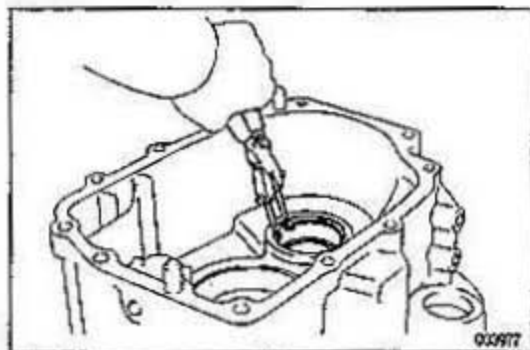

2. REPLACE COUNTER GEAR FRONT BEARING OUTER RACE

- (a) Using snap ring pliers, remove the snap ring.

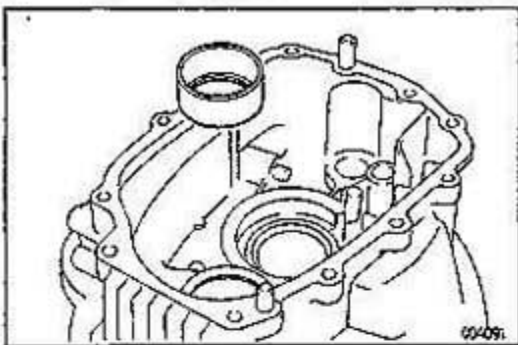

- (b) Heat the front case in boiling water.
[80 – 90°C (176 – 194°F)]
- (c) Remove the counter bearing outer race.

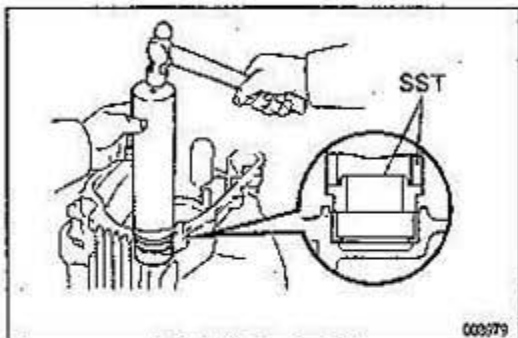

- (d) Heat the front case in boiling water.
[80 – 90°C (176 – 194°F)]
- (e) Apply gear oil to a new outer race and install it to the front case.
- (f) Using SST and a hammer, tap the counter bearing outer race.
SST 09308–14010, 09309–14020

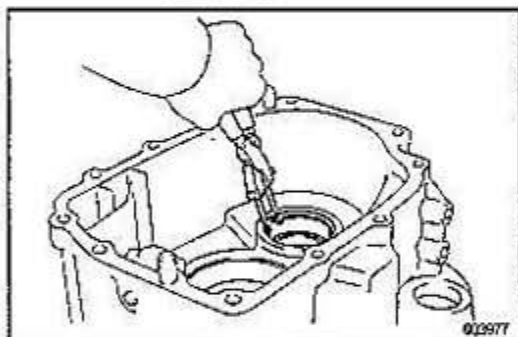

- (g) Using snap ring pliers, install the snap ring.

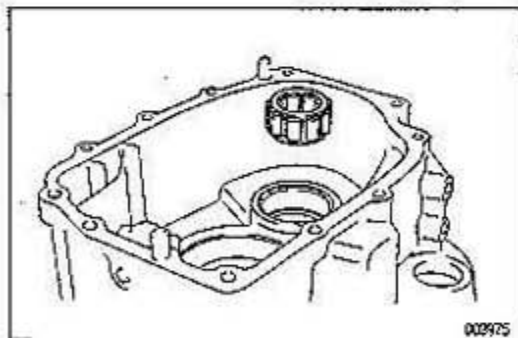

FRONT CASE ASSEMBLY

M7086-01

1. **INSTALL COUNTER GEAR FRONT BEARING**
Apply gear oil to the bearing and install it to the front case.

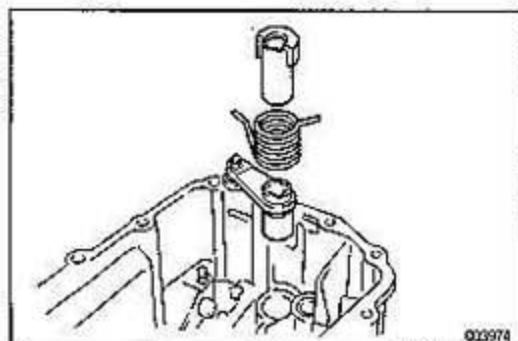

2. **INSTALL RETURN SPRING ASSEMBLY**
 - (a) Install the return spring assembly to the front case.

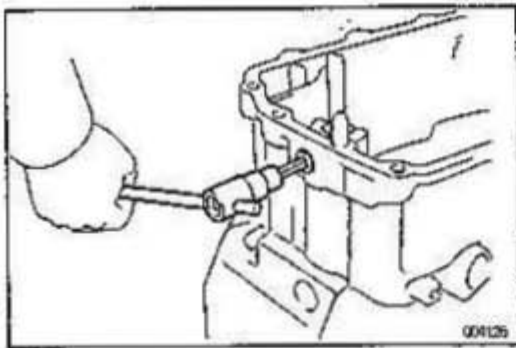

- (b) Using a hexagon wrench, install and torque the bolt.
Torque: 10 N·m (100 kgf·cm, 7 ft·lbf)

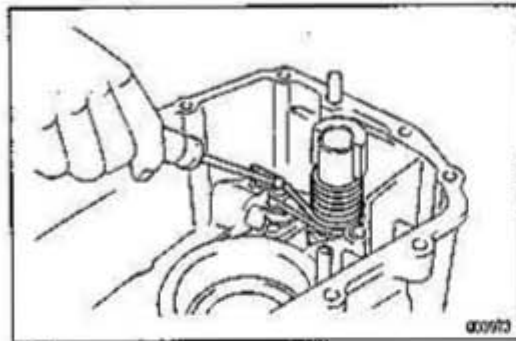

- (c) Using a screwdriver, engage the end of the spring.

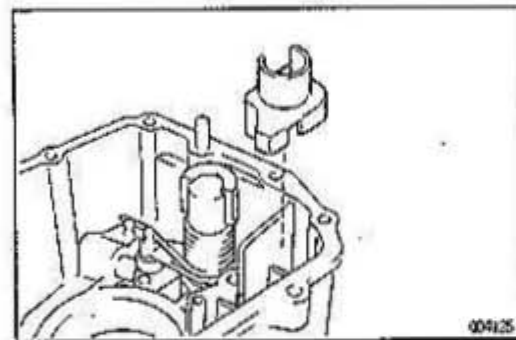

3. INSTALL OIL RECEIVER

INTERMEDIATE PLATE COMPONENTS

MTM2-01

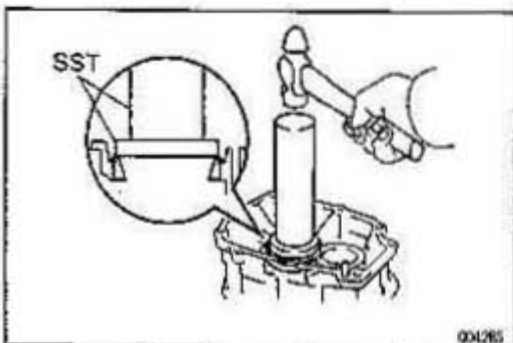
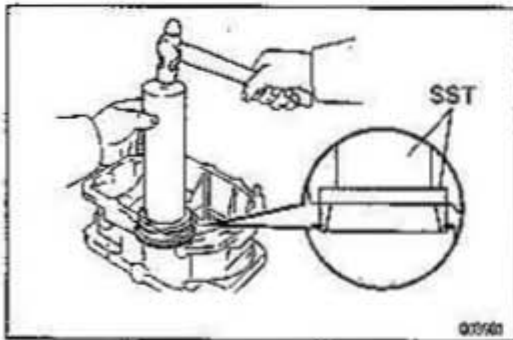
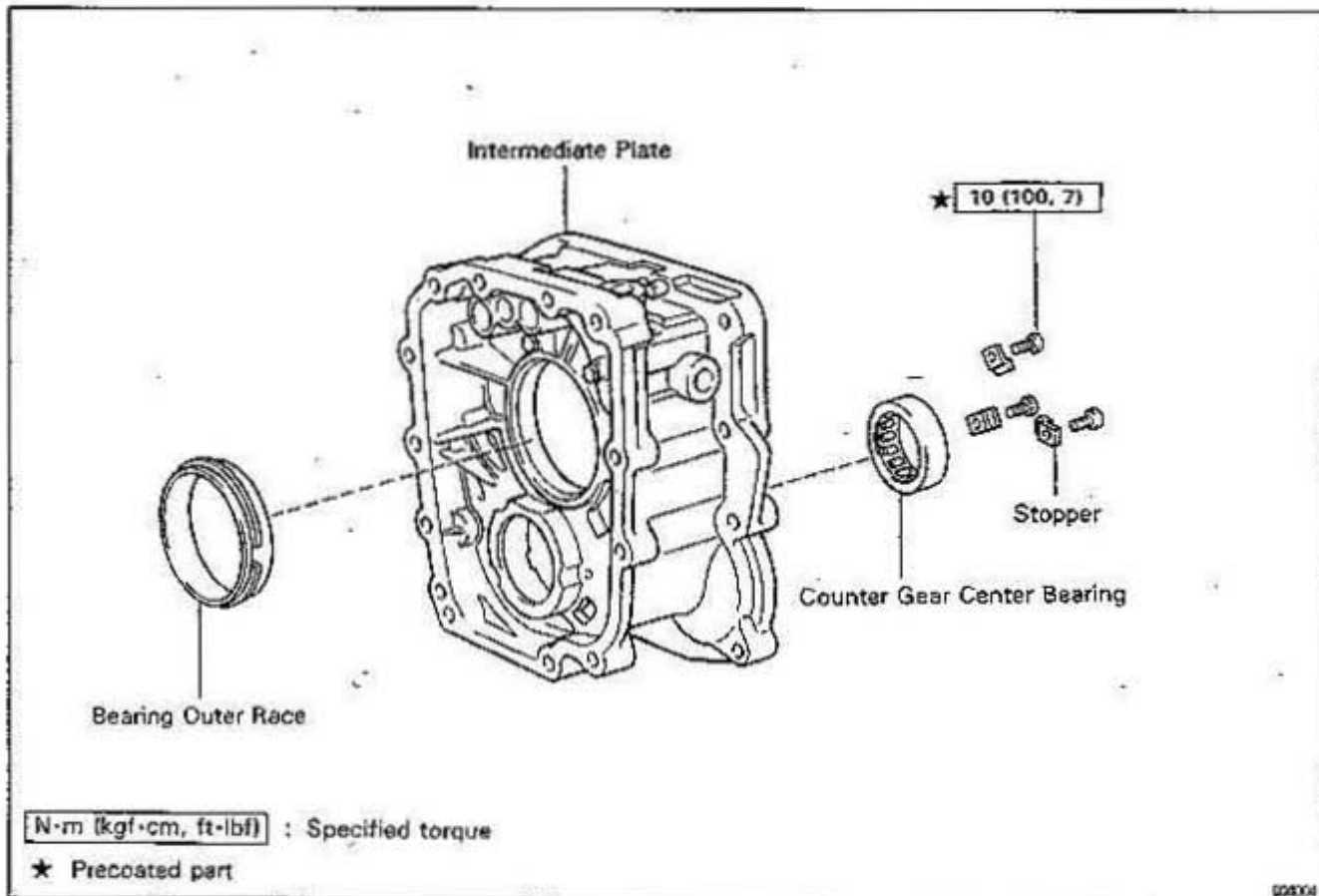

INTERMEDIATE PLATE COMPONENT — PARTS REPLACEMENT

MTM2-01

1. REPLACE OUTPUT SHAFT CENTER BEARING OUTER RACE

- Heat the intermediate plate in boiling water.
[80 – 90°C (176 – 194°F)]
- Using SST and a hammer, remove the outer race.
SST 09308–14010, 09309–14050
- Heat the intermediate plate in boiling water.
[80 – 90°C (176 – 194°F)]
- Apply gear oil to the outer race and install it to the intermediate plate.
- Using SST and a hammer, tap the outer race.
SST 09308–14010, 09309–14050

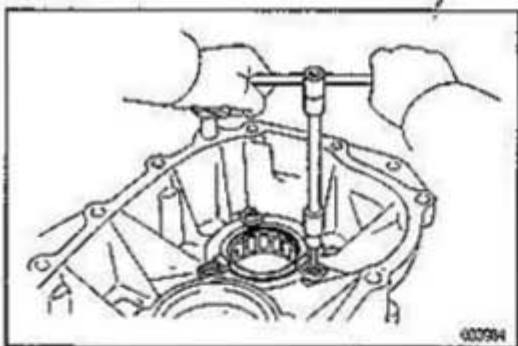

- 2. REPLACE COUNTER GEAR CENTER BEARING**
- (a) Using a hexagon wrench, remove the 3 bolts and 3 stoppers.
 - (b) Heat the intermediate plate in boiling water. [80 – 90°C (176 – 194°F)]
 - (c) Remove the bearing from the intermediate plate.

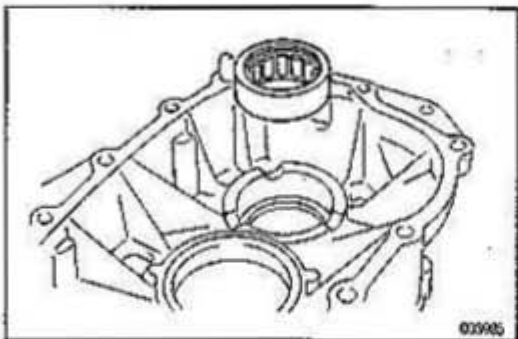

- (d) Heat the intermediate plate in boiling water. [80 – 90°C (176 – 194°F)]
- (e) Apply gear oil to the bearing and install it to the intermediate plate.

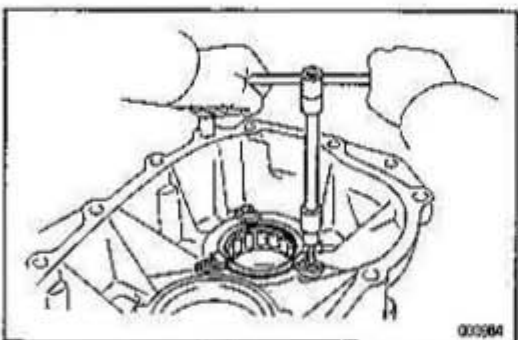

- (f) Apply sealant to the bolts threads.
Sealant:
Part No.08833–00080, THREE BOND 1344, LOC-TITE 242 or equivalent
- (g) Install the 3 stoppers and torque the 3 bolts with hexagon wrench.
Torque: 10 N·m (100 kgf·cm, 7 ft·lbf)

REAR CASE COMPONENTS

M756-01

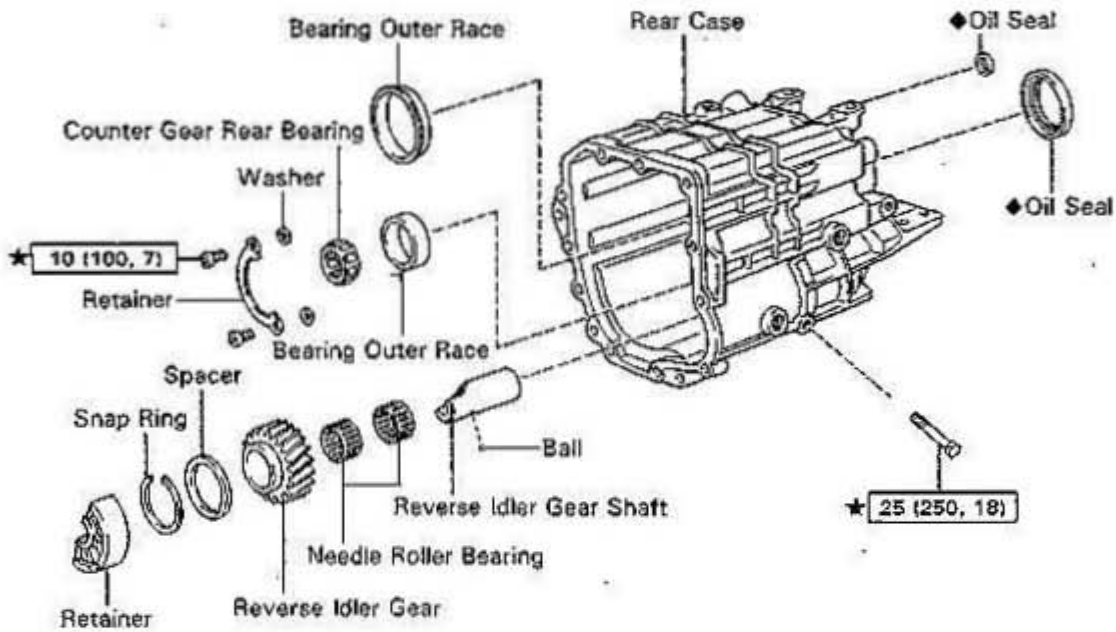

N·m (kgf·cm, ft·lbf) : Specified torque

◆ Non-reusable part

★ Precoated part

004005

REAR CASE DISASSEMBLY

M756A-01

1. MEASURE REVERSE IDLER GEAR THRUST CLEARANCE

Using a feeler gauge, measure the idler gear thrust clearance.

Maximum clearance:

0.20 mm (0.0079 in.)

If the clearance is more than the limit, replace the gear, needle roller bearing or shaft.

2. REMOVE REVERSE IDLER GEAR

(a) Remove the set bolt.

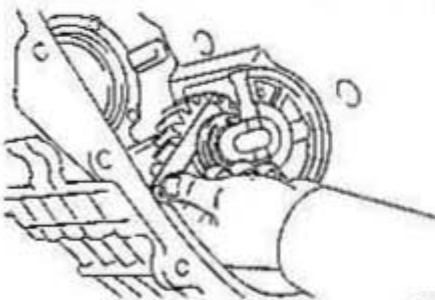

003917

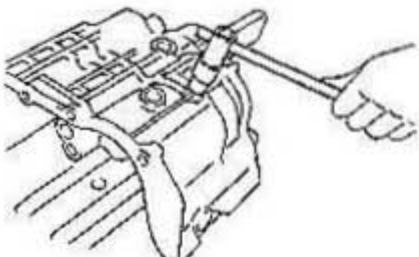

003906



- (b) Remove the following parts from the rear case.
- Retainer
 - Idler gear shaft
 - Ball
 - Spacer
 - Reverse idler gear
 - 2 needle roller bearings.

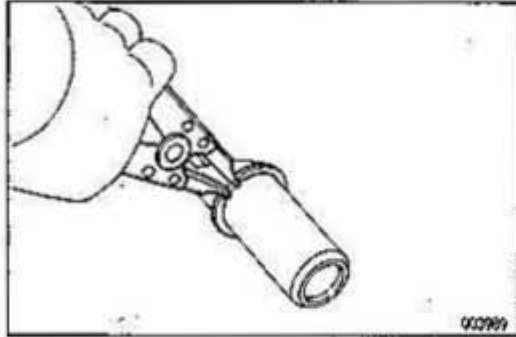

- (c) Using a snap ring expander, remove the snap ring from the idler gear shaft.
NOTICE: Take care to not scratch the idler gear shaft.

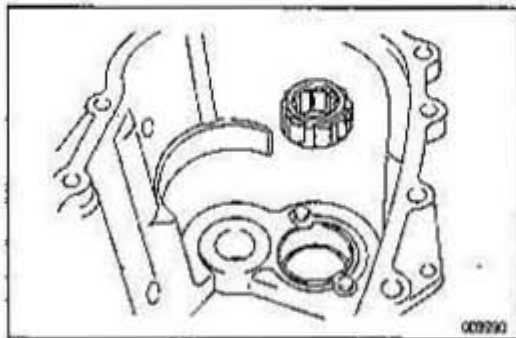

3. REMOVE COUNTER GEAR REAR BEARING

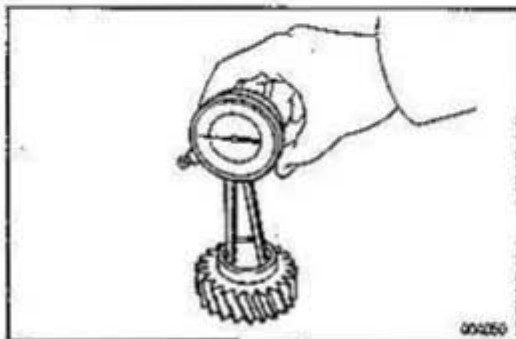

REAR CASE COMPONENT PARTS INSPECTION

- 1. INSPECT REVERSE IDLER GEAR INSIDE DIAMETER**
 Using a dial gauge, measure the inside diameter of reverse idler gear.

Maximum clearance:

35.03 mm (1.3791 in.)

If the inside diameter exceeds the maximum, replace the gear.

- 2. INSPECT REVERSE IDLER GEAR SHAFT**

Using a micrometer, measure the outer diameter of the reverse idler gear shaft.

Minimum diameter:

29.99 mm (1.1807 in.)

If the outer diameter is less than the minimum, replace the shaft.

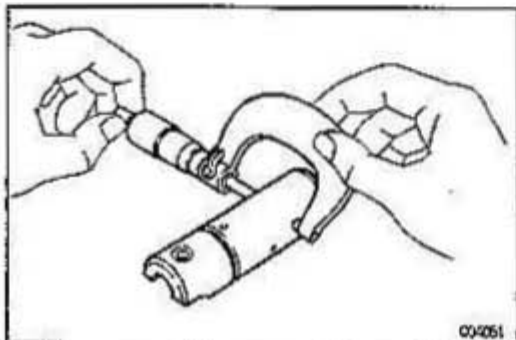

REAR CASE COMPONENT PARTS REPLACEMENT

1. REPLACE OUTPUT SHAFT OIL SEAL AND BEARING OUTER RACE

- (a) Using a screwdriver and hammer, drive out the output shaft oil seal.

- (b) Using SST and a hammer, drive out the output shaft rear bearing outer race.

SST 09308-14010, 09309-14030

- (c) Heat the rear case in boiling water.
[80 – 90°C (176 – 194°F)]

- (d) Apply gear oil to a new output shaft rear bearing outer race and install it to the rear case.

- (e) Using SST and a hammer, tap the outer race.

SST 09308-14010, 09309-14050

- (f) Using SST and a hammer, install a new output shaft oil seal.

SST 09308-14010, 09309-14040

2. REPLACE COUNTER GEAR REAR BEARING OUTER RACE

- (a) Using a hexagon wrench, remove the 2 bolts, retainer and 2 washers.

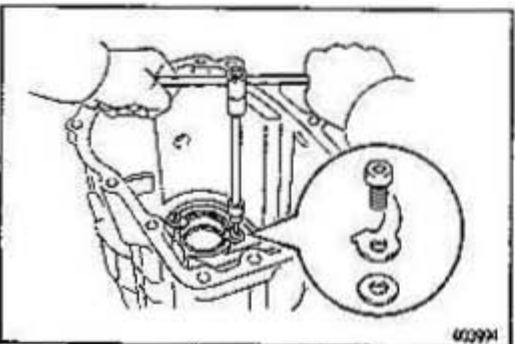
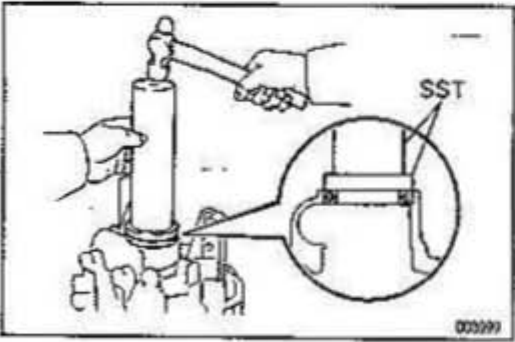
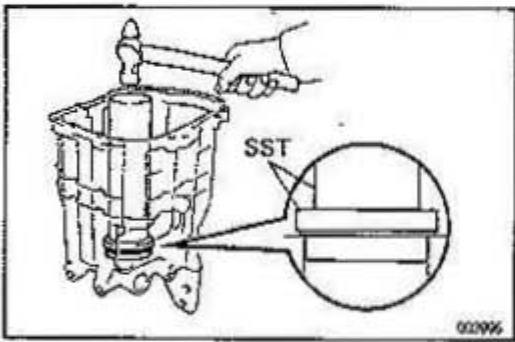
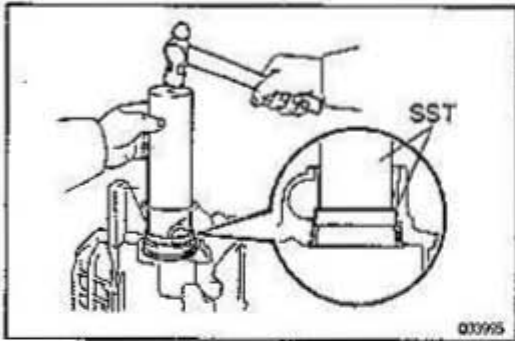
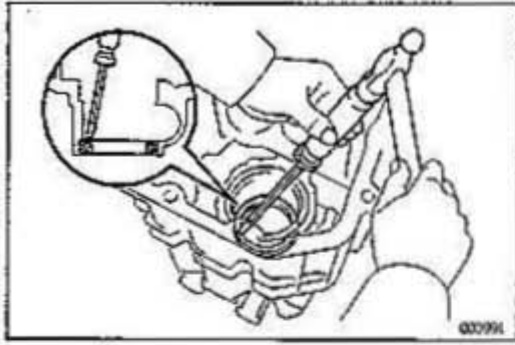

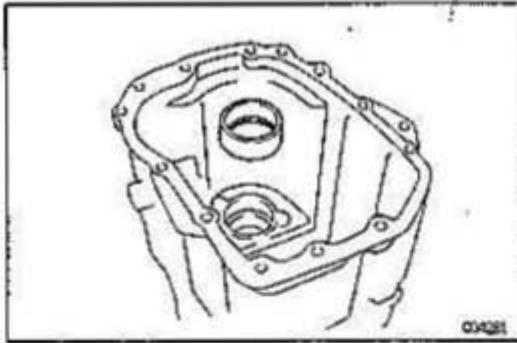

- (b) Heat the rear case in boiling water.
[80 – 90°C (176 – 194°F)]
- (c) Remove the counter rear bearing outer race.

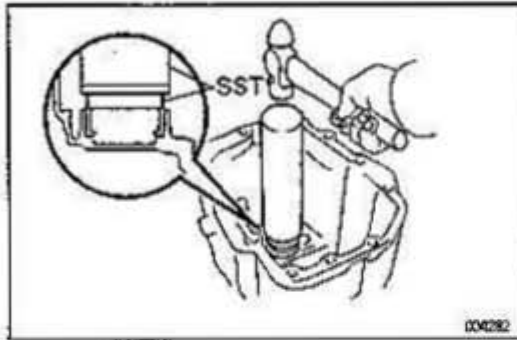

- (d) Heat the rear case in boiling water.
[80 – 90°C (176 – 194°F)]
- (e) Apply gear oil to a new counter rear bearing outer race and install it to the rear case.
- (f) Using SST and a hammer, tap the outer race.
SST 09308–14010, 09309–14020

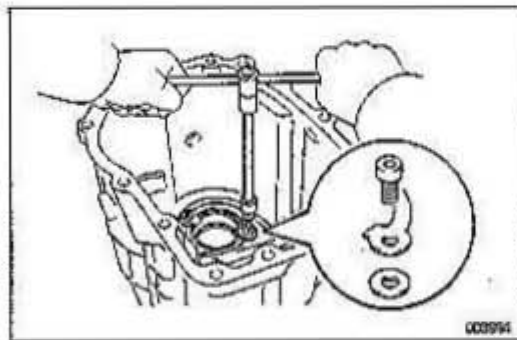

- (g) Install the 2 washers and retainer.
- (h) Apply sealant to the bolts threads.
Sealant:
Part No.08833–00080, THREE BOND 1344, LOC-
TITE 242 or equivalent
- (i) Using a hexagon wrench, torque the 2 bolts.
Torque: 10 N·m (100 kgf·cm, 7 ft·lbf)

3. REPLACE MAIN CONTROL ROD OIL SEAL

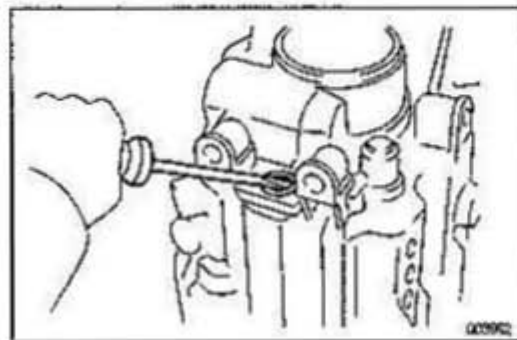

- (a) Using a screwdriver, pry out the main control rod oil seal.

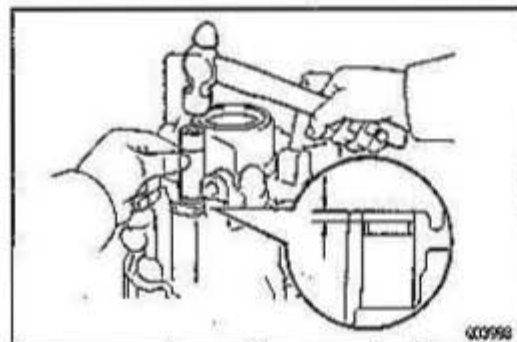

- (b) Using a plug wrench and hammer, install a new oil seal.
Drive in depth:
3.0 mm (0.118 in.)

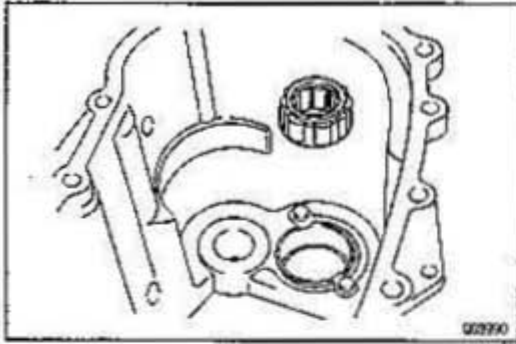

REAR CASE ASSEMBLY

1. INSTALL COUNTER GEAR REAR BEARING

Apply gear oil to the bearing and install it to the rear case.

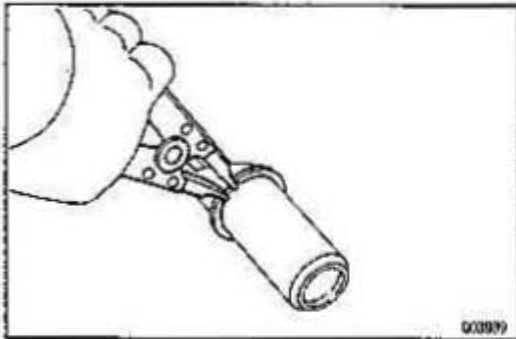

2. INSTALL REVERSE IDLER GEAR

(a) Select a new snap ring that will allow minimum axial play.

Snap ring thickness mm (in.)	Snap ring thickness mm (in.)
1.55–1.60 (0.0611–0.0630)	1.85–1.90 (0.0728–0.0748)
1.85–1.70 (0.0650–0.0669)	1.95–2.00 (0.0768–0.0787)
1.75–1.80 (0.0690–0.0709)	

(b) Using a snap ring expander, install the snap ring to the idler gear shaft.

NOTICE:

- Do not expand the snap ring more than is necessary.
- Take care to not scratch the idler gear shaft.

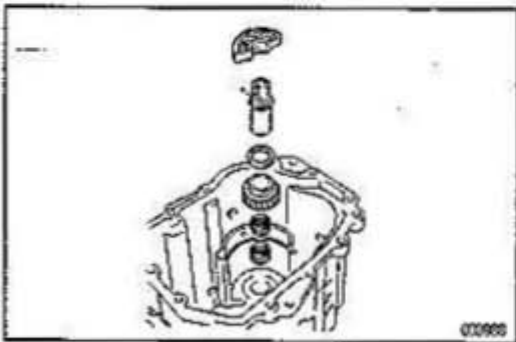

(c) Install the following parts to the rear case.

HINT: Coat all of the sliding and rotating surface with gear oil before assembly.

- 2 needle roller bearings
- Reverse idler gear
- Spacer
- Ball
- Idler gear shaft
- Retainer

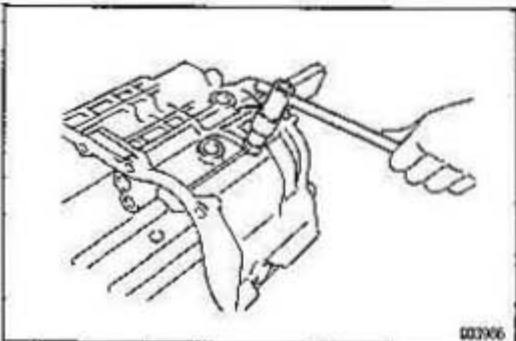

(d) Apply sealant to the bolt threads.

Sealant:

Part No.08833–00080, THREE BOND 1344, LOC-TITE 242 or equivalent

(e) Install and torque the set bolt.

Torque: 25 N·m (250 kgf·cm, 18 ft·lbf)

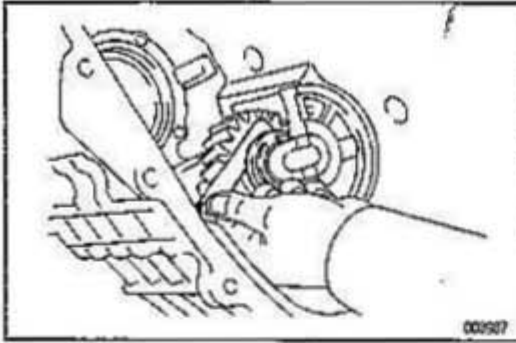

3. INSPECT REVERSE IDLER GEAR THRUST CLEARANCE

Using a feeler gauge, measure the idler gear thrust clearance.

Maximum clearance:

0.20 mm (0.0079 in.)

COMPONENT PARTS INSTALLATION BASIC SUBASSEMBLY REASSEMBLY

(See pages MT-9 and MT-10)

1. STAND OUTPUT SHAFT AND COUNTER GEAR

- (a) Stand the output shaft and counter gear upright on the SST so that the front of the transmission is facing upward.

SST 09310-14010

NOTICE: Adjust the output shaft nut so that the 4th counter gear and 4th gear are the same height.

- (b) Inspect the neutral position.

2. INSTALL 1-2, 3-4, REVERSE SHIFT FORK AND MAIN CONTROL ROD

- (a) Place the 1-2, 3-4, reverse shift forks into the groove of hub sleeves.
- (b) Place the main control rod to the 1-2 and reverse fork shafts.

- (c) Set the lock slider to the shift forks.

3. INSTALL INTERMEDIATE PLATE

Install the intermediate plate to the output shaft and counter gear.

4. INSTALL LOCK SLIDER SET BOLTS

Hold the lock plate still with pliers while tighten the 2 bolts.

Torque: 10 N·m (100 kgf·cm, 7 ft·lbf)

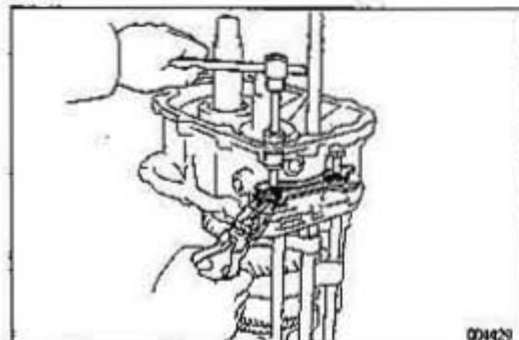
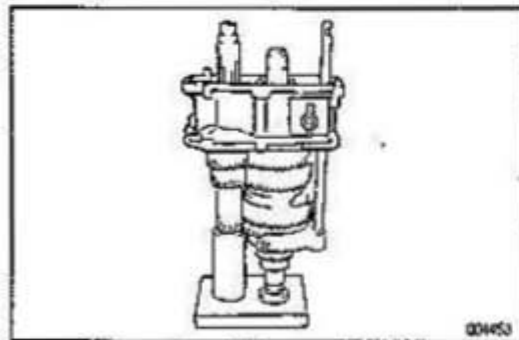
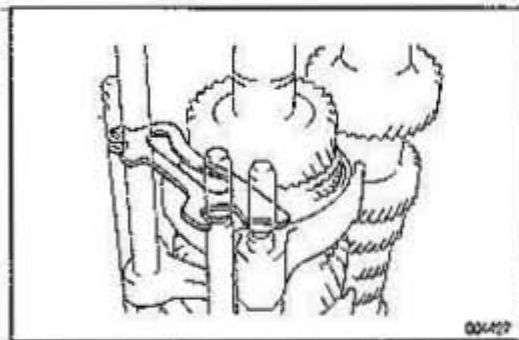
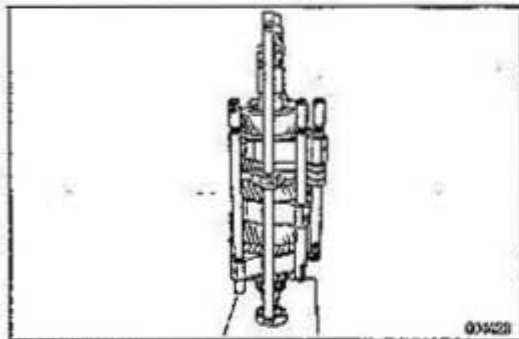
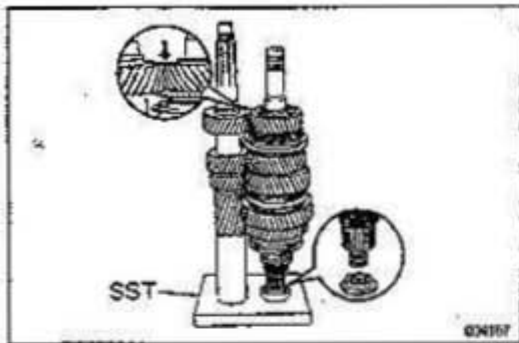

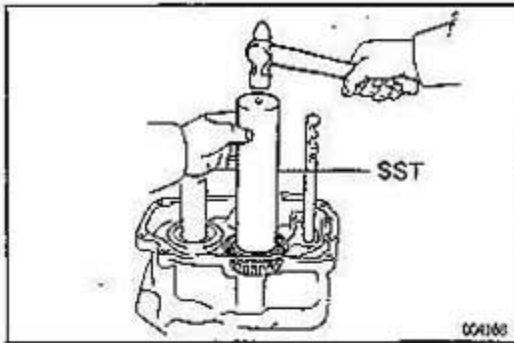

5. INSTALL OUTPUT SHAFT FRONT BEARING

- (a) Heat a new roller bearing in an oven. [100 – 110°C (212 – 230°F)]
CAUTION: Take care to avoid burns.
- (b) Apply gear oil to the output shaft and install the bearing to the output shaft.
- (c) Using SST and a hammer, tap the bearing.
SST 09308–14010
NOTICE: Perform the remaining steps after the bearing has returned to normal temperature.
- (d) Cut a new shim and install it to the output shaft.

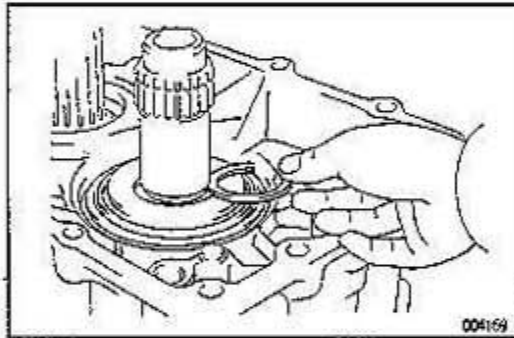
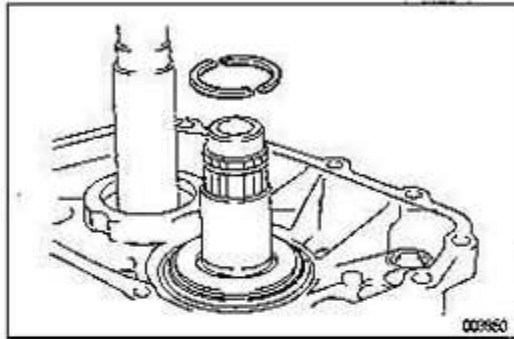

- (e) Select a new snap ring that will allow minimum axial play.

Thickness mm (in.)	Thickness mm (in.)
1.87–1.90 (0.0737–0.0748)	2.07–2.10 (0.0815–0.0827)
1.92–1.95 (0.0756–0.0768)	2.12–2.15 (0.0835–0.0846)
1.97–2.00 (0.0776–0.0787)	2.17–2.20 (0.0854–0.0866)
2.02–2.05 (0.0795–0.0807)	

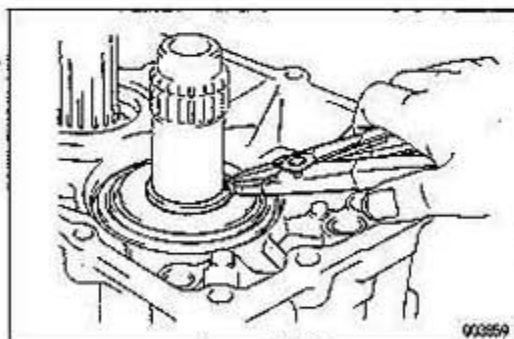

- (f) Using a snap ring expander, install the snap ring.
NOTICE: –
 - Do not expand the snap ring more than is necessary.
 - Take care to not scratch the output shaft.

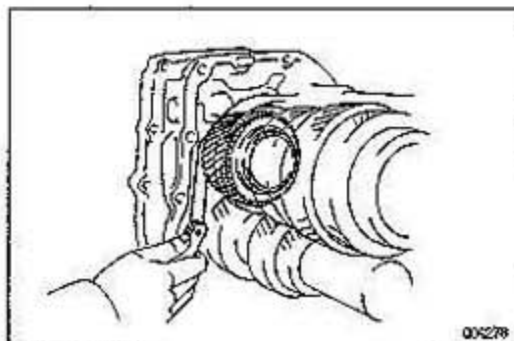

6. INSPECT 4TH GEAR THRUST CLEARANCE

Using a feeler gauge, measure the 4th gear thrust clearance.

Maximum clearance:

0.26 mm (0.0102 in.)

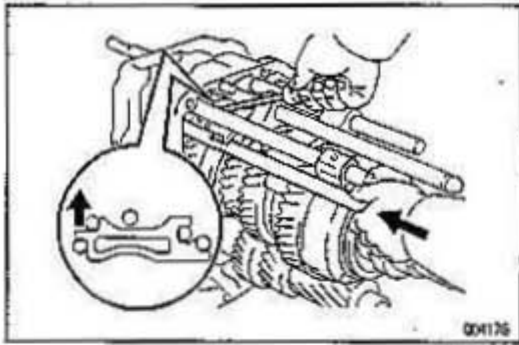
**7. INSTALL SHIFT RAIL**

Install the shift rail while lifting the lock slider upward.

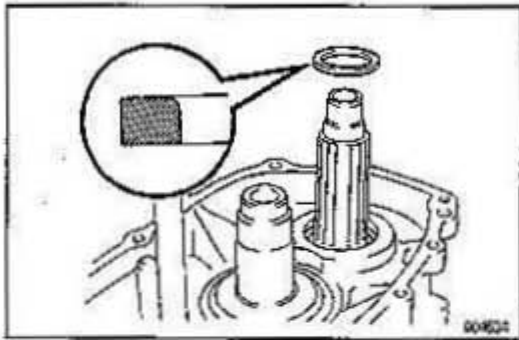
**8. INSTALL 6TH COUNTER GEAR**

- (a) Install the washer to the counter gear shaft.

NOTICE: Install the washer so that the chamfered inner edge of the washer faces outward.

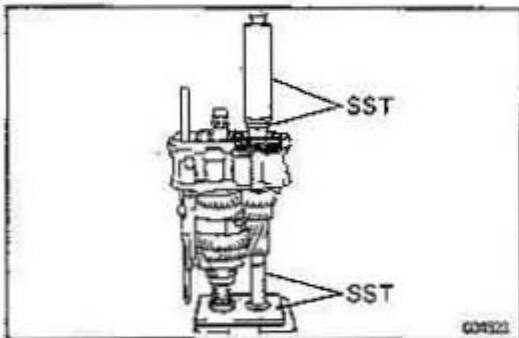

- (b) Heat the 6th counter gear in an oven.
[130°C (266°F)]

CAUTION: The gear is hot, so handle it with heat proof gloves.

- (c) Apply gear oil to the counter gear shaft.
(d) Using SST and a press, install the 6th counter gear.
SST 09308-14010, 09308-14030, 09309-14010,
09310-14010

Torque: 240 N·m (2,500 kgf·cm, 177 ft·lbf)

NOTICE: Perform the remaining steps after the counter gear has returned to normal temperature.

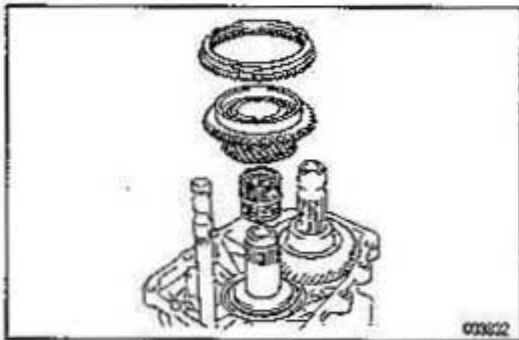
**9. INSTALL 6TH GEAR**

- (a) Place the synchronizer ring on the gear.
(b) Apply gear oil to the needle roller bearing.
(c) Install the needle roller bearing and 6th gear to the output shaft.

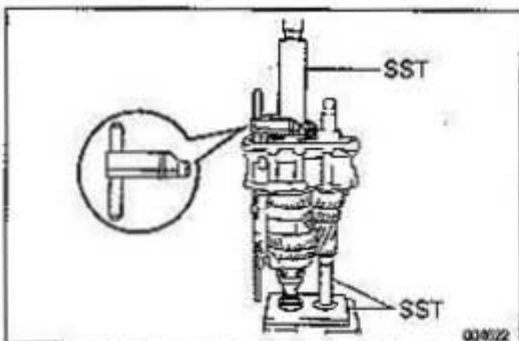
10. INSTALL 5-6 HUB SLEEVE ASSEMBLY, 5-6 SHIFT FORK AND FORK SHAFT

- (a) Place the 5-6 shift fork into the groove of 5-6 hub sleeve.
(b) Using SST and a press, install the 5-6 hub sleeve assembly, 5-6 shift fork and fork shaft.
SST 09308-14010, 09308-14030, 09310-14010

NOTICE:

- Take care that the hub sleeve does not come apart from the clutch hub when you remove it.
- Align the synchronizer ring tab with the groove in the clutch hub.

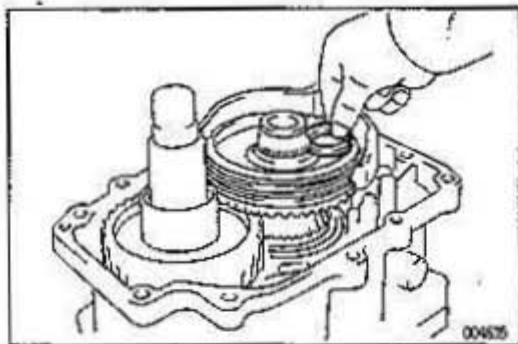

(c) Select a snap ring that will allow minimum axial play.

Thickness mm (in.)	Thickness mm (in.)
1.87-1.90 (0.0737-0.0748)	2.07-2.10 (0.0815-0.0827)
1.92-1.95 (0.0758-0.0768)	2.12-2.15 (0.0835-0.0846)
1.97-2.00 (0.0776-0.0787)	2.17-2.20 (0.0854-0.0866)
2.02-2.05 (0.0795-0.0807)	

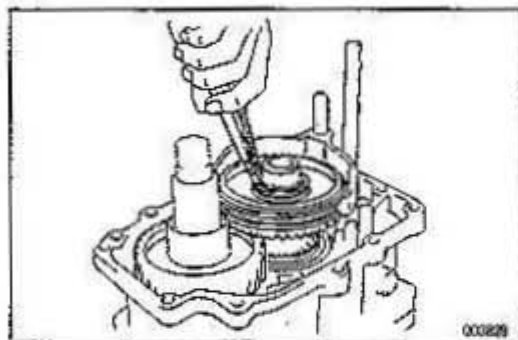

(d) Using a new snap ring expander, install the snap ring.
NOTICE:

- Do not expand the snap ring more than is necessary.
- Take care to not scratch the output shaft.

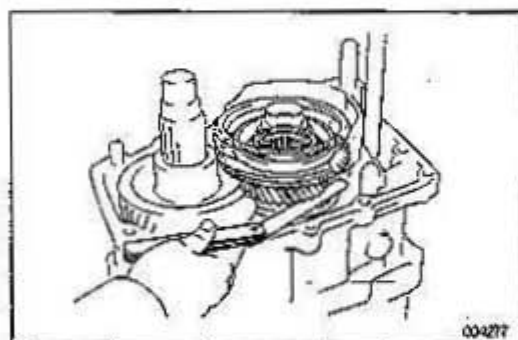

11. INSPECT 6TH GEAR THRUST CLEARANCE

Using a feeler gauge, measure the 6th gear thrust clearance.

Maximum clearance:

0.33 mm (0.0130 in.)

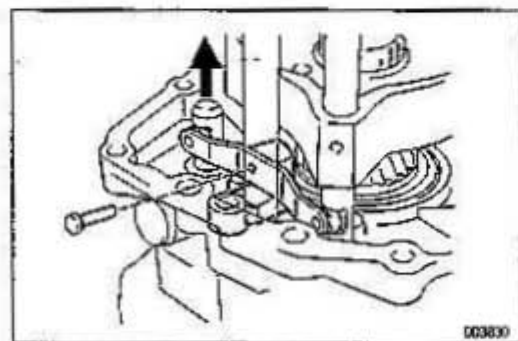

12. INSTALL RETURN LEVER

- (a) Apply MP grease to the return lever.
(b) Install the return lever to the intermediate plate.

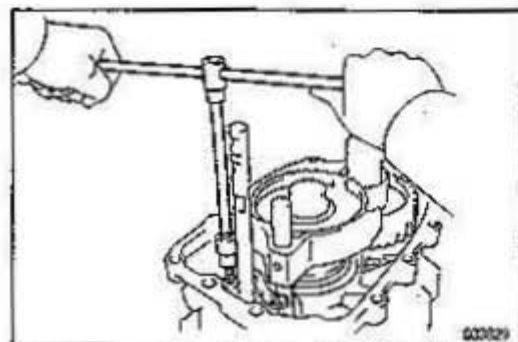

(c) Apply seal packing to the bolt threads.

Sealant:

Part No.08833-00080, THREE BOND 1344, LOC-TITE 242 or equivalent

(d) Using a hexagon wrench, install and torque the set bolt.

Torque: 25 N-m (250 kgf-cm, 18 ft-lbf)

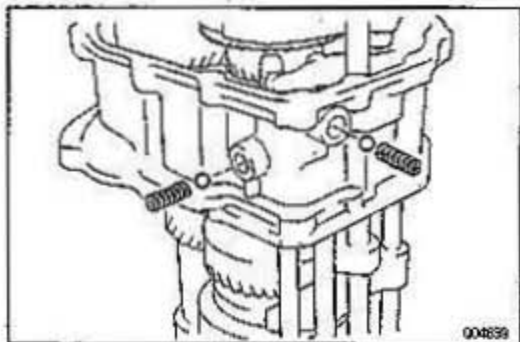
**13. INSTALL LOCK BALLS FOR INTERMEDIATE PLATE**

(a) Install the 2 springs and 2 balls.

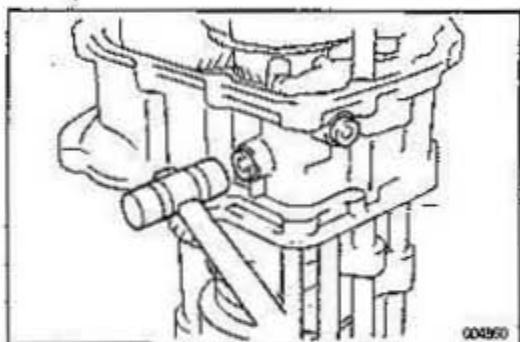

(b) Using a plastic hammer, install the 2 plugs.

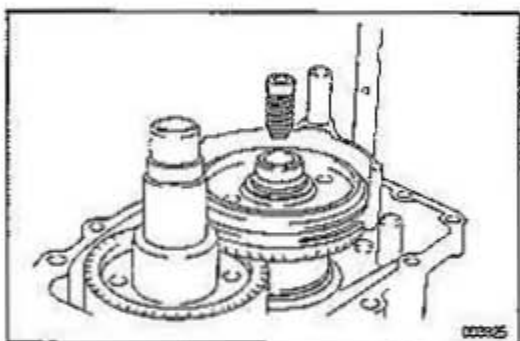
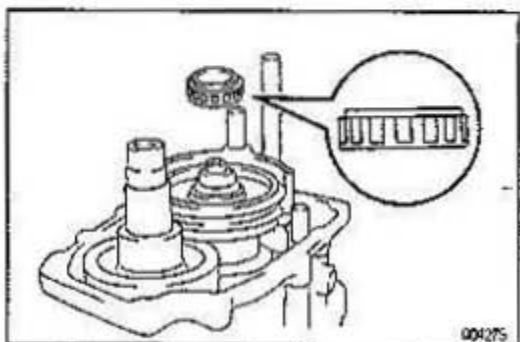
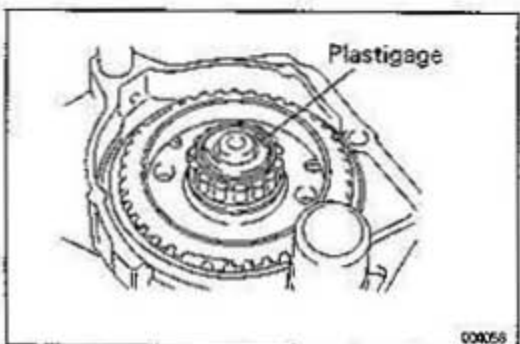
**14. INSTALL SPRING FOR ADJUSTING PRELOAD****15. INSTALL OUTPUT SHAFT FRONT BEARING****16. SELECT INPUT SHAFT BEARING SHIM**

(a) Lay a strip of Plastigage on the output shaft.

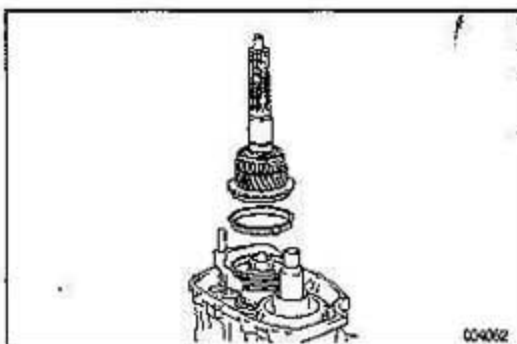

(b) Install the input shaft to the output shaft.

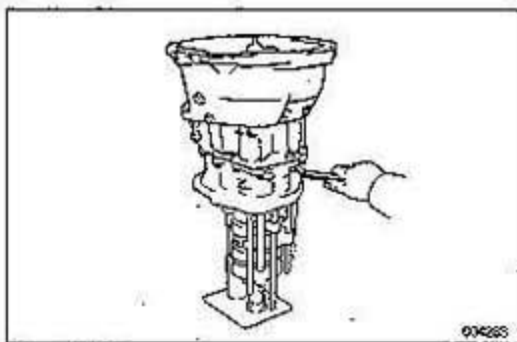

(c) Install the front case.

(d) Install and torque the 11 bolts.

Torque: 22 N·m (220 kgf·cm, 16 ft·lbf)

NOTICE: Do not turn input shaft.

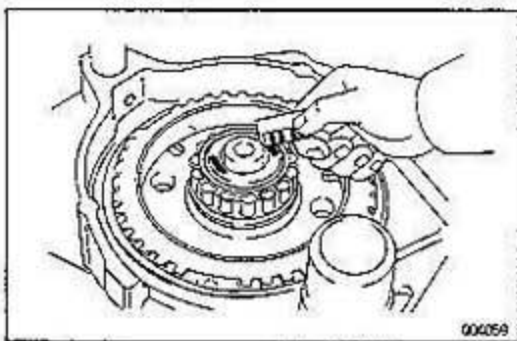

(e) Remove the 11 bolts and front case.

(f) Measure the Plastigage at its widest point.

(g) Calculate the required thickness of the adjusting shim.

Thickness:

$$\text{(Minimum thickness shim + Measurement)} \\ + (0.05 \sim 0.15 \text{ mm}, 0.0020 \sim 0.0059 \text{ in.})$$

Adjusting shim thickness mm (in.)	Adjusting shim thickness mm (in.)
0.97-1.00 (0.0382-0.0394)	1.57-1.80 (0.0618-0.0630)
1.02-1.05 (0.0402-0.0414)	1.62-1.65 (0.0638-0.0650)
1.07-1.10 (0.0422-0.0433)	1.67-1.70 (0.0658-0.0669)
1.12-1.15 (0.0441-0.0453)	1.72-1.75 (0.0677-0.0689)
1.17-1.20 (0.0461-0.0472)	1.77-1.80 (0.0697-0.0709)
1.22-1.25 (0.0481-0.0492)	1.82-1.85 (0.0717-0.0729)
1.27-1.30 (0.0500-0.0512)	1.87-1.90 (0.0737-0.0748)
1.32-1.35 (0.0520-0.0532)	1.92-1.95 (0.0756-0.0768)
1.37-1.40 (0.0540-0.0551)	1.97-2.00 (0.0776-0.0787)
1.42-1.45 (0.0559-0.0571)	2.00-2.05 (0.0787-0.0807)
1.47-1.50 (0.0579-0.0591)	2.05-2.10 (0.0807-0.0827)
1.52-1.55 (0.0599-0.0611)	

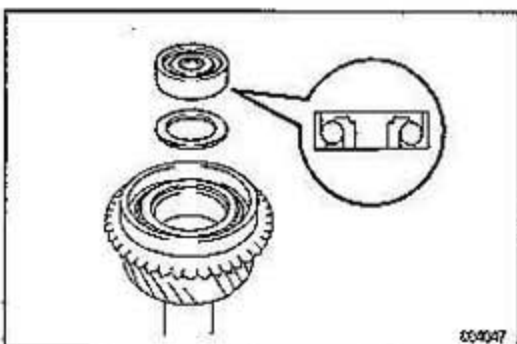

17. INSTALL INPUT SHAFT AND 5TH COUNTER GEAR

(a) Install the selected shim and ball bearing to the input shaft.

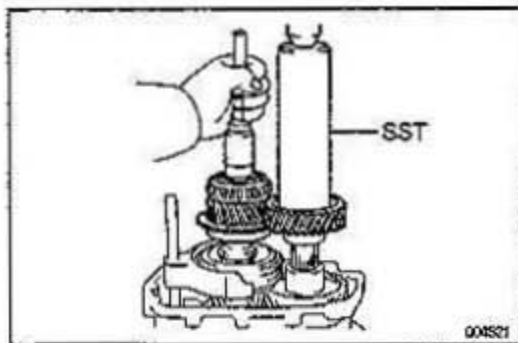

- (b) Heat the 5th counter gear in an oven.
[130°C (266°F)]
- (c) Apply gear oil to the counter gear shaft.
- (d) Using SST and a press, install the counter 5th gear together with the input shaft.
SST 09308-14010, 09310-14010
NOTICE: Perform the remaining steps after the counter gear has returned to normal temperature.

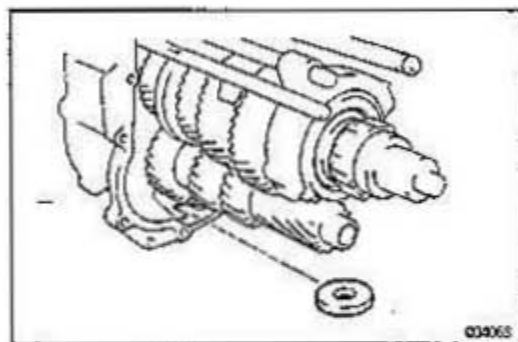

18. INSTALL MAGNET TO INTERMEDIATE PLATE

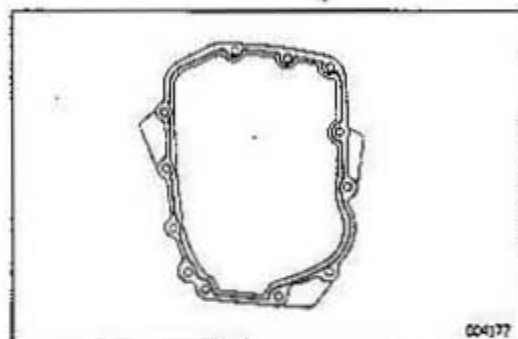

19. INSTALL REAR CASE

- (a) Remove any FIPG material and be careful not to drop oil on the contacting surface of the intermediate plate or rear case.
- (b) Apply FIPG to the rear case as shown in the illustration and install it to the intermediate plate.

FIPG:

Part No.08833-00090, THREE BOND 1281 or equivalent

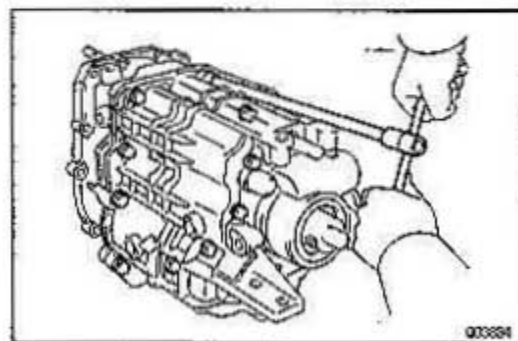

- (c) Install and torque the 10 bolts.
Torque: 22 N·m (220 kgf·cm, 16 ft·lb)

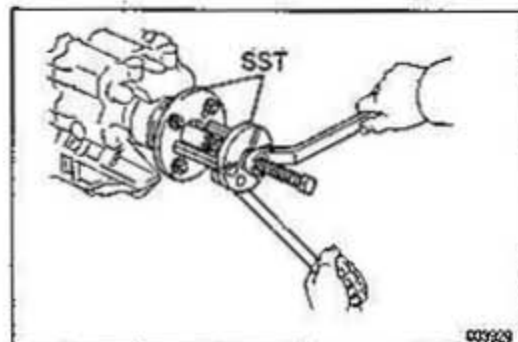

20. INSTALL COMPANION FLANGE

- (a) Heat the companion flange in an oven.
[80 - 90°C (176 - 194°F)]
- (b) Apply gear oil to the output shaft and install the companion flange.
- (c) Using SST, install the companion flange to the output shaft.
SST 09950-30010 (09951-03010, 09953-03010,
09954-03010, 09955-03030, 09956-03030)

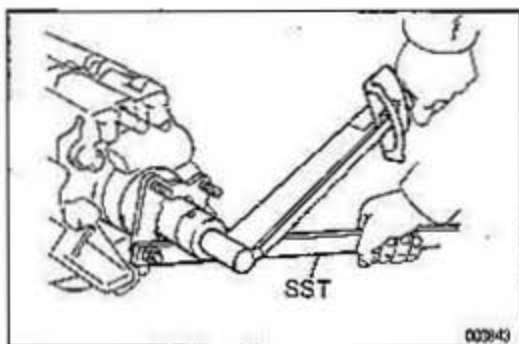

- (d) Using SST to hold the flange, install and torque the lock nut.

SST 09330-00021

Torque: 190 N·m (1,940 kgf·cm, 140 ft·lbf)

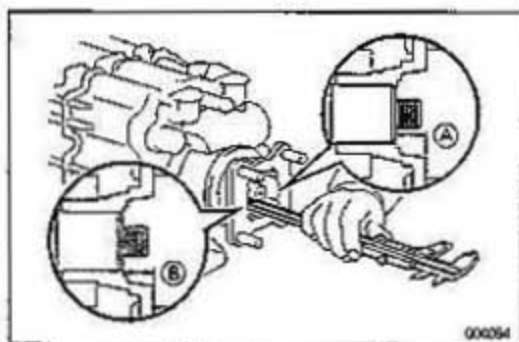

- (e) Remove the lock nut.
 (f) Using a caliper gauge, measure dimension (A) and dimension (B).

- (g) Calculate the required thickness of the adjusting shim.
 Thickness:

$$(\text{Dimension (A)} - \text{Dimension (B)}) - (0.05 \sim 0.14 \text{ mm}, 0.0020 \sim 0.0055 \text{ in.})$$

Adjusting shim thickness mm (in.)	Adjusting shim thickness mm (in.)
1.15-1.20 (0.0453-0.0472)	1.65-1.70 (0.0650-0.0669)
1.25-1.30 (0.0492-0.0512)	1.85-1.90 (0.0729-0.0748)
1.45-1.50 (0.0571-0.0591)	1.95-2.00 (0.0768-0.0787)

- (h) Install the selected shim to the output shaft.

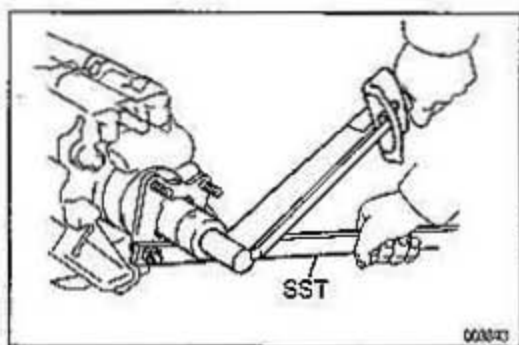

- (i) Apply seal packing to the nut threads.

Sealant:

Part No. 08833-00080, THREE BOND 1344,
 LOCTITE 242 or equivalent

- (j) Using SST to hold the flange, reinstall and torque the lock nut.

SST 09330-00021

Torque: 120 N·m (1,220 kgf·cm, 88 ft·lbf)

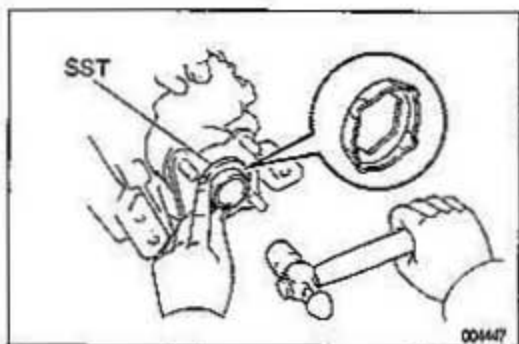

- (k) Using SST and a hammer, tap in a new lock plate.

SST 09309-14010

HINT: If necessary, using a pin punch and hammer, tap the lock plate.

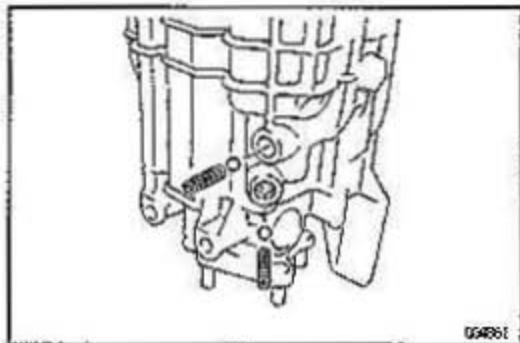
**21. INSTALL LOCK BALLS FOR REAR CASE**

- (a) Install the 2 springs and 2 balls.

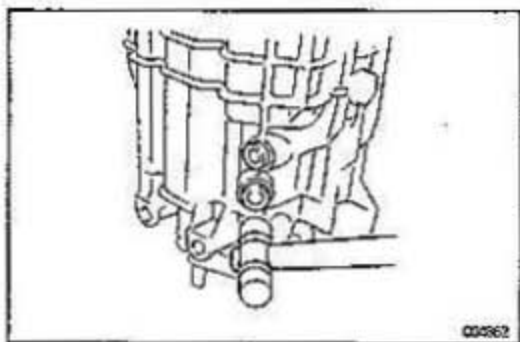

- (b) Using a plastic hammer, install the 2 plugs.

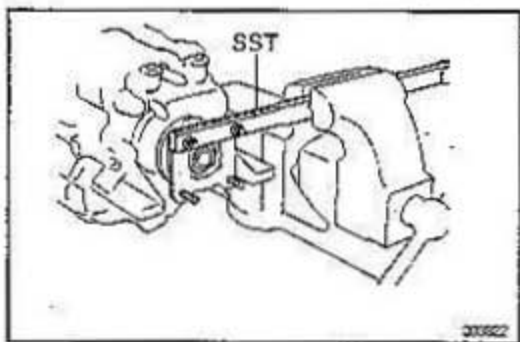
**22. INSTALL COUNTER GEAR LOCK NUT**

- (a) Using SST, set the transmission as shown in the illustration.

SST 09330-00021

- (b) Engage the gear.

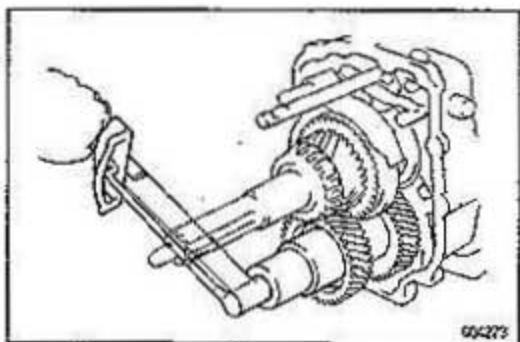

- (c) Using a deep socket wrench, torque the lock nut.
Torque: 226 N-m (2,300 kgf-cm, 166 ft-lbf)

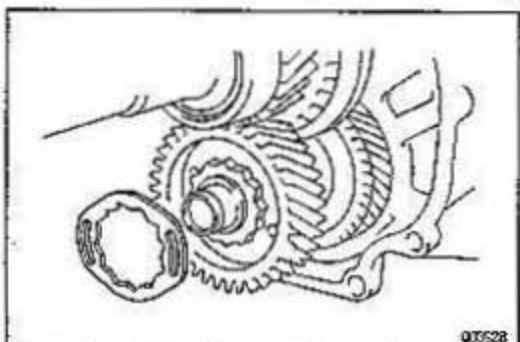

- (d) Install the lock nut plate.

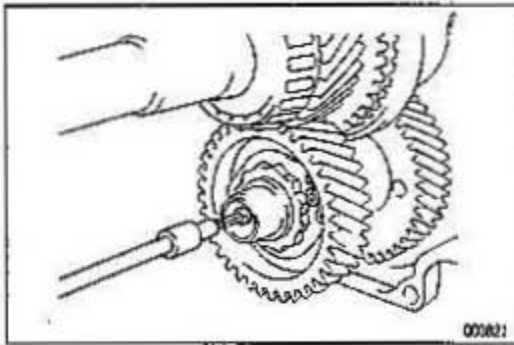

- (e) Apply sealant to the bolt threads.

Sealant:

Part No.08833-00080, THREE BOND 1344, LOC-TITE 242 or equivalent

- (f) Using a hexagon wrench, torque the 2 washers and 2 bolts.

Torque: 5.9 N·m (60 kgf·cm, 52 in·lbf)

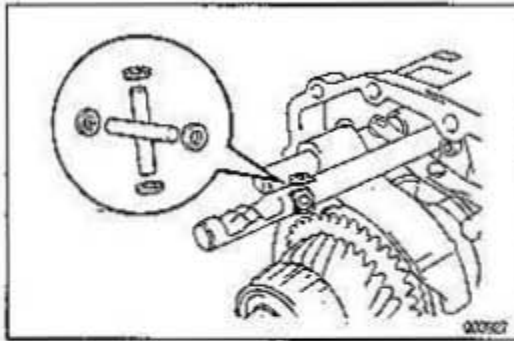

23. INSTALL PINS AND ROLLERS

- (a) Apply MP grease to the pins and rollers.
 (b) Install the 2 pins and 4 rollers to the main control rod.

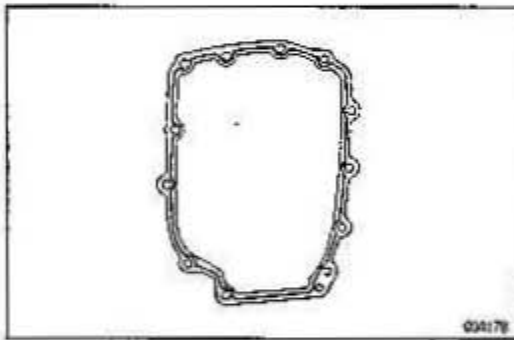

24. INSTALL FRONT CASE

- (a) Remove any FIPG material and be careful not to drop oil on the contacting surface of the intermediate plate or front case.
 (b) Apply FIPG to the rear case as shown in the illustration and install it to the intermediate plate.

FIPG:

Part No.08833-00090, THREE BOND 1281 or equivalent

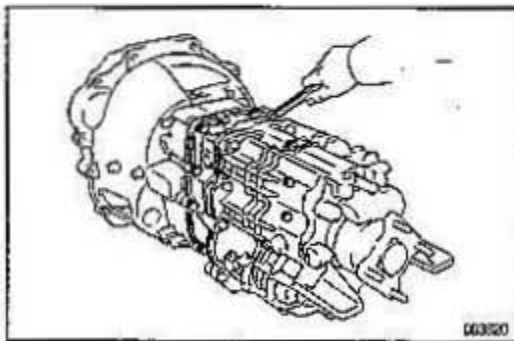

- (c) Install and torque the 11 bolts.

Torque: 22 N·m (220 kgf·cm, 16 ft·lbf)

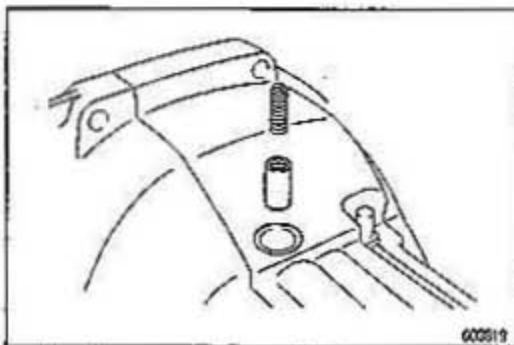

25. INSTALL LOCK BALL ASSEMBLY

- (a) Install the spring seat and spring.

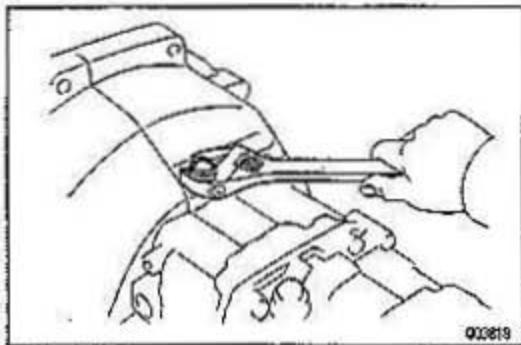

- (b) Apply sealant to the plug threads.

Sealant:

Part No.08833-00080, THREE BOND 1344, LOC-TITE 242 or equivalent

- (c) Install and torque the plug.

Torque: 30 N·m (310 kgf·cm, 22 ft·lbf)

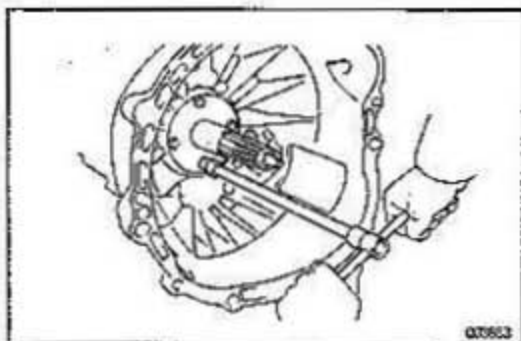

26. INSTALL FRONT BEARING RETAINER

- (a) Install the front bearing retainer with the 4 bolts.

Torque: 10 N·m (100 kgf·cm, 7 ft·lbf)

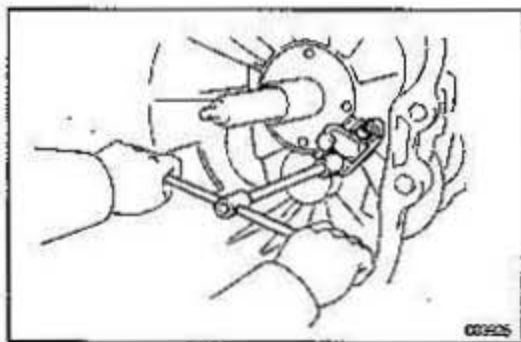

- (b) Install the clutch release fork support with the 2 bolts.

Torque: 25 N·m (260 kgf·cm, 19 ft·lbf)

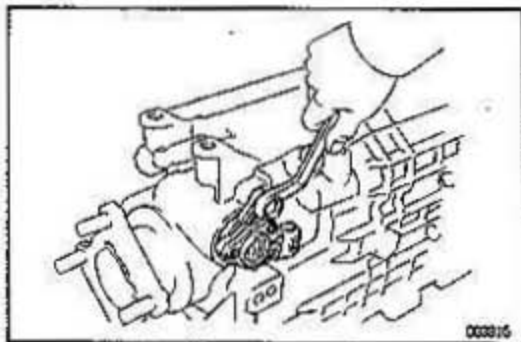

27. INSTALL SPEED SENSOR DRIVEN GEAR

- (a) Install a new O-ring to the driven gear.

- (b) Apply sealant to the bolt threads.

Sealant:

Part No.08833-00080, THREE BOND 1344, LOC-TITE 242 or equivalent

- (c) Install the driven gear with a bolt.

Torque: 11 N·m (110 kgf·cm, 8 ft·lbf)

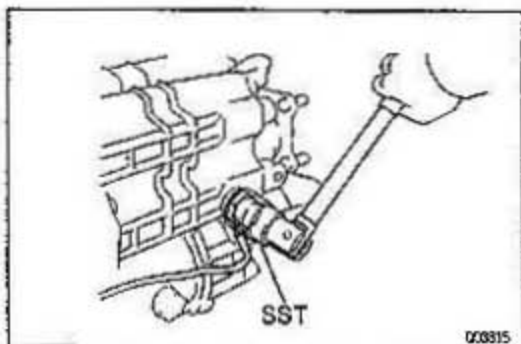

28. INSTALL BACK-UP LIGHT SWITCH

Using SST, install and torque the back-up light switch and a new gasket.

SST 09817-16011

Torque: 40 N·m (410 kgf·cm, 30 ft·lbf)

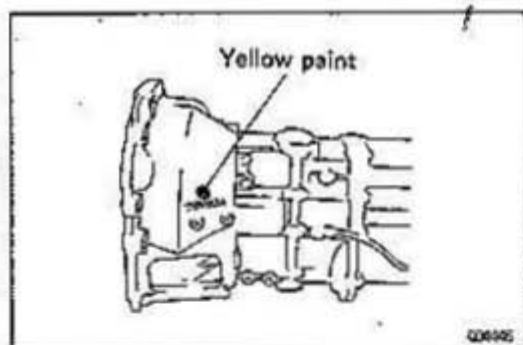
**29. APPLY YELLOW PAINT**

When the transmission has been overhauled, apply yellow paint to the front case as shown in the illustration in order to identify the transmission as an overhauled one.

SERVICE SPECIFICATIONS

MT62-01

SERVICE DATA

Output shaft			
1st gear inner race diameter	Limit	52.95 mm	2.0845 in.
2nd gear journal diameter	Limit	52.99 mm	2.0862 in.
3rd gear journal diameter	Limit	49.99 mm	1.9681 in.
4th gear journal diameter	Limit	41.99 mm	1.6531 in.
5th gear journal diameter	Limit	36.99 mm	1.4553 in.
Reverse gear inner race diameter	Limit	52.95 mm	2.0848 in.
Flange thickness	Limit	5.2 mm	0.205 in.
Runout	Limit	0.05 mm	0.0020 in.
Counter gear			
Front bearing journal diameter	Limit	26.01 mm	1.0240 in.
Center bearing journal diameter	Limit	35.00 mm	1.3779 in.
Rear bearing journal diameter	Limit	26.01 mm	1.0240 in.
Gear thrust clearance			
1st & 2nd	Limit	0.26 mm	0.0102 in.
3rd	Limit	0.18 mm	0.0071 in.
4th	Limit	0.26 mm	0.0102 in.
5th	Limit	0.33 mm	0.0130 in.
Reverse	Limit	0.18 mm	0.0071 in.
Reverse idler	Limit	0.20 mm	0.0079 in.
Gear radial clearance			
1st	Limit	0.09 mm	0.0035 in.
2nd	Limit	0.06 mm	0.0024 in.
3rd & 4th	Limit	0.05 mm	0.0020 in.
Reverse	Limit	0.08 mm	0.0031 in.
Gear inside diameter			
1st	Limit	58.03 mm	2.2846 in.
2nd	Limit	58.03 mm	2.2846 in.
3rd	Limit	55.03 mm	2.1665 in.
4th	Limit	47.00 mm	1.8504 in.
Reverse	Limit	58.03 mm	2.2846 in.
Shift fork to hub sleeve clearance	Limit	0.7 mm	0.028 in.
Synchronizer ring to gear clearance	Limit	1.1 mm	0.043 in.
Output shaft snap ring thickness			
3 — 4 clutch hub		2.01 — 2.05 mm	0.0791 — 0.0807 in.
		1.96 — 2.00 mm	0.0772 — 0.0787 in.
		1.91 — 1.95 mm	0.0752 — 0.0768 in.
		1.86 — 1.90 mm	0.0733 — 0.0748 in.
		1.81 — 1.85 mm	0.0713 — 0.0729 in.
		1.76 — 1.80 mm	0.0693 — 0.0709 in.

5 – 6 clutch hub	1.87 – 1.90 mm	0.0737 – 0.0748 in.
	1.92 – 1.95 mm	0.0756 – 0.0768 in.
	1.97 – 2.00 mm	0.0776 – 0.0787 in.
	2.02 – 2.05 mm	0.0795 – 0.0807 in.
	2.07 – 2.10 mm	0.0815 – 0.0827 in.
	2.12 – 2.15 mm	0.0835 – 0.0846 in.
	2.17 – 2.20 mm	0.0854 – 0.0866 in.
Front bearing	1.87 – 1.90 mm	0.0737 – 0.0748 in.
	1.92 – 1.95 mm	0.0756 – 0.0768 in.
	1.97 – 2.00 mm	0.0776 – 0.0787 in.
	2.02 – 2.05 mm	0.0795 – 0.0807 in.
	2.07 – 2.10 mm	0.0815 – 0.0827 in.
	2.12 – 2.15 mm	0.0835 – 0.0846 in.
	2.17 – 2.20 mm	0.0854 – 0.0866 in.
Reverse idler gear shaft snap ring thickness	1.55 – 1.60 mm	0.0611 – 0.0630 in.
	1.65 – 1.70 mm	0.0650 – 0.0669 in.
	1.75 – 1.80 mm	0.0690 – 0.0709 in.
	1.85 – 1.90 mm	0.0729 – 0.0748 in.
	1.95 – 2.00 mm	0.0768 – 0.0787 in.

TORQUE SPECIFICATIONS

MT-63-01

Part tightened	N-m	kgf-cm	ft-lbf
Return spring set bolt	10	100	7
Counter gear center bearing set bolt	10	100	7
Counter gear rear bearing outer race set bolt	10	100	7
Reverse idler gear shaft set bolt	25	250	18
Intermediate plate x Rear case	22	220	16
Companion flange lock nut	120	1,220	88
6th counter gear installation torque	240	2,500	177
Return lever set bolt	25	250	18
Front case x Intermediate plate	22	220	16
5th counter gear lock nut	226	2,300	166
Lock plate set bolt	5.9	60	52 in.-lbf
Lock ball assembly	30	310	22
Front bearing retainer set bolt	10	100	7
Clutch release fork support set bolt	25	260	19
Speed sensor set bolt	11	110	8
Back-up light switch	40	410	30
Lock slider set bolt	10	100	7

TOYOTA
QUALITY SERVICE

**RSEAS SERVICE DIVISION
TOYOTA MOTOR CORPORATION**

PRINTED IN JAPAN
First Printing: Sep. 9, 1993 01-930909-00